

DS-130-64-3SH

Absolute position, rotary Electric Encoder™

The DS-130 is a member of the DS series of Electric Encoders™, based on Netzer Precision proprietary technology. The Electric Encoder™ offers many advantages - some unparalleled

Low profile (10 mm).
 Hollow, floating shaft.
 No bearings or other contacting elements.
 High resolution and precision.
 High tolerance to temperature extremes , shock, moisture, EMI, RFI and Magnetic fields.
 Very low weight.
 Holistic signal generation
 Digital interfaces.

Mechanical

Allowable mounting eccentricity	±0.1 mm
Allowable rotor axial motion	±0.1 mm
Rotor inertia	12.378 gr · mm ²
Total weight	65 gr
Outer Ø /Inner Ø/ Height	130 / 90 / 10 mm
Material (stator, rotor)	Ultem™ polymer

Electrical

Supply voltage	5V ± 5%
Interconnection	Shielded cable or
Cable Length	1,500 mm MAX

Environmental

EMC	IEC 6100-6-2, IEC 6100-6-4
Operating temperature range	Digital: -40°C to +85°C
Relative humidity	98% Non condensing
Shock endurance	100 g for 11 ms
Vibration endurance	20 g 10 – 2000 Hz
Protection	IP 40

Characteristics

Angular resolution	19 bits ; 524,288 CPR
Static error	< 10 mDeg
Maximum operational speed	750 rpm
Measurement range	Unlimited rotation
Power On - Max. operational speed	3.3 RPM , <=20°/sec
Build In Test BIT	Optional

The Electric Encoder™ is unique in being holistic, i.e., its output reading is the averaged outcome of the whole area of the rotor , This feature makes the Electric Encoder™ forgiving to mounting tolerances, mechanical wander etc. The absence of components such as ball bearings , flexible couplers, glass disc, light sources and detectors, along with very low power consumption makes the Electric Encoder™ virtually failure free. The internally shielded, DC operated Electric Encoder™ includes an electric field generator, a field receiver, a sinusoidal shaped dielectric rotor, and processing electronics.

The output signals of Electric Encoder™ are analog Sine / Cosine representing the rotation angle. The digital outputs are obtained by further processing - which may be either internal or external to the encoder.

The combination of precision, low profile, low weight and high reliability have made Netzer Precision encoders particularly suitable to a wide variety of critical applications including, but not limited to medical equipment and aerospace.

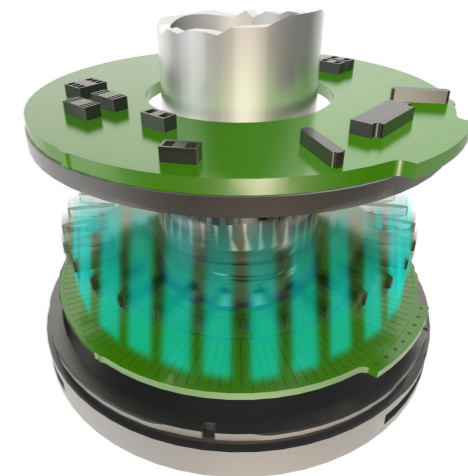
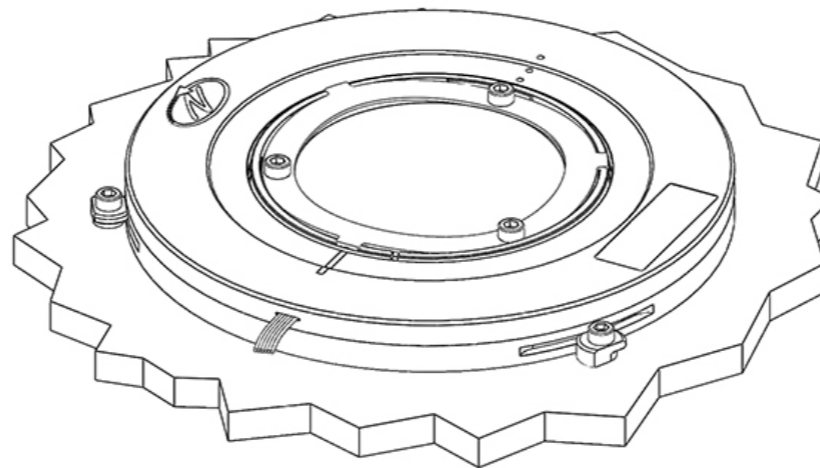
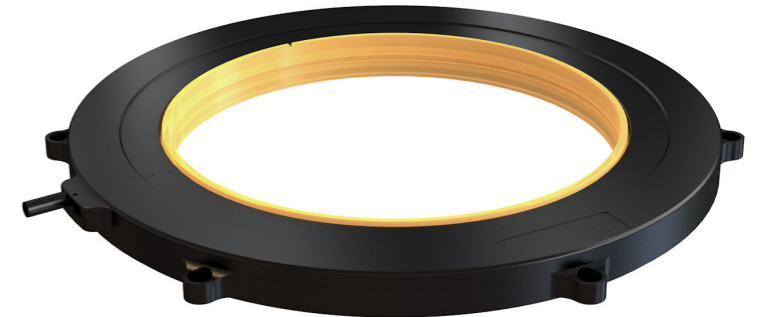



DS-130-64-35H Absolute position, rotary Electric Encoder™



Digital SSI Interface

Synchronous Serial Interface (**SSI**) is a point to point serial interface standard between a master (e.g. controller) and a slave (e.g. sensor) for digital data transmission.

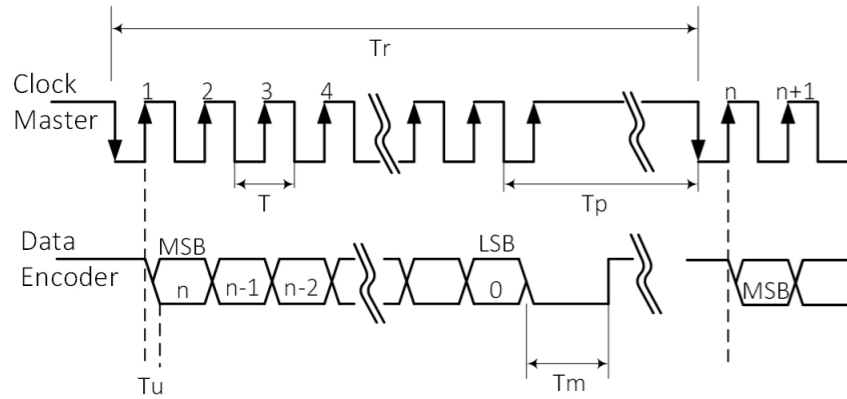

	Description	Recommendations
n	Total number of data bits	12- 22
T	Clock period	
f= 1/T	Clock frequency	0.5 - 2.0 MHz
Tu	Bit update time	200 nsec
Tp	Pause time	26 - ∞ μsec
Tm	Monoflop time	>25 μsec
Tr	Time between 2 adjacent requests	Tr > n*T+26 μsec
fr=1/Tr	Data request frequency	

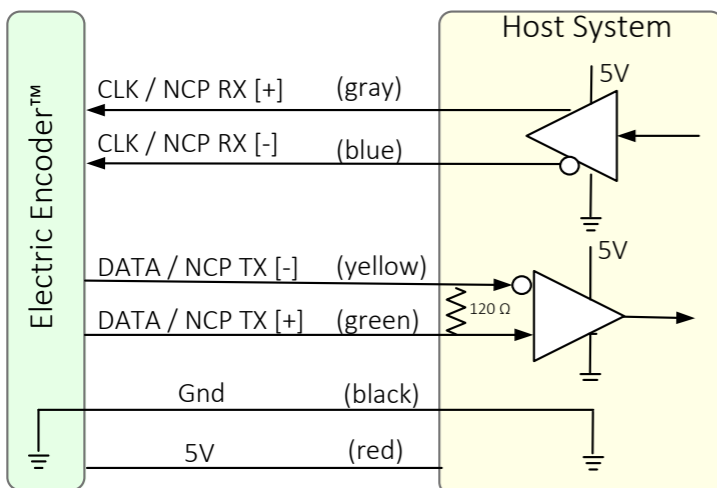

SSI / BiSS Output signal parameters

Signal latency	~250 μSec
Output code	Binary
Serial output	Differential RS-422
Clock	Differential RS-422
Clock Frequency	0.5 ÷ 2.0 MHz
Position update rate (Max)	30 KHz
Current consumption	180 mA

SSI	
Monoflop time	25 μSec

SSI / BiSS interface wires color code

Clock +	Grey	Clock
Clock -	Blue	
Data -	Yellow	Data
Data +	Green	
GND	Black	Ground
+5V	Red	Power supply

Software tools: (SSI / BiSS - C)

Advanced calibration and monitoring options are available by using the factory supplied **Electric Encoder Explorer** software, This facilitates proper mechanical mounting, offsets calibration and advanced signal monitoring.

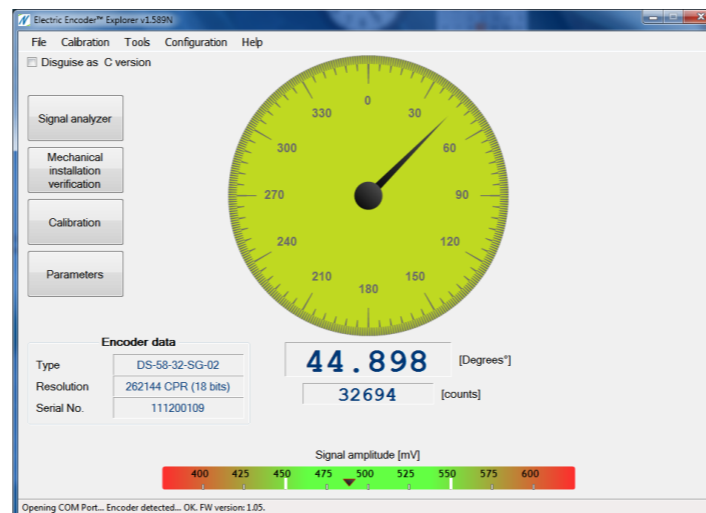

Digital BiSS-C Interface

BiSS - C Interface is unidirectional serial synchronous protocol for digital data transmission where the Encoder acts as "slave" transmits data according to "Master" clock. The BiSS protocol is designed in B mode and C mode (continuous mode) .The BiSS-C interface as the SSI is based on RS-422 standards.

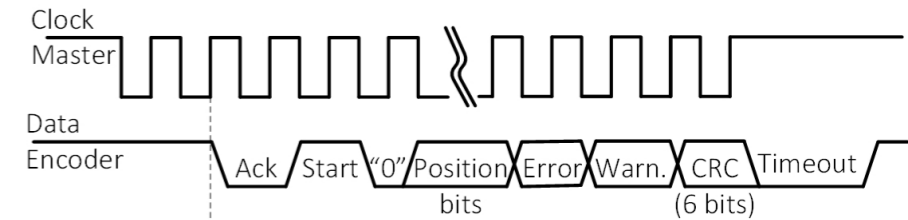

bit #	Description	Default	Length
29	Ack	0	1/clock
28	Start	1	1 bit
27	"0"	0	1 bit
8...26	AP		
7	Error	1	1 bit
6	Warn.	1	1 bit
0...5	CRC		6 bits
	Timeout		25 μs



DS-130-64-3SH Absolute position, rotary Electric Encoder™

DS - 130 - 64 - 3 S H - S 0 - n n n

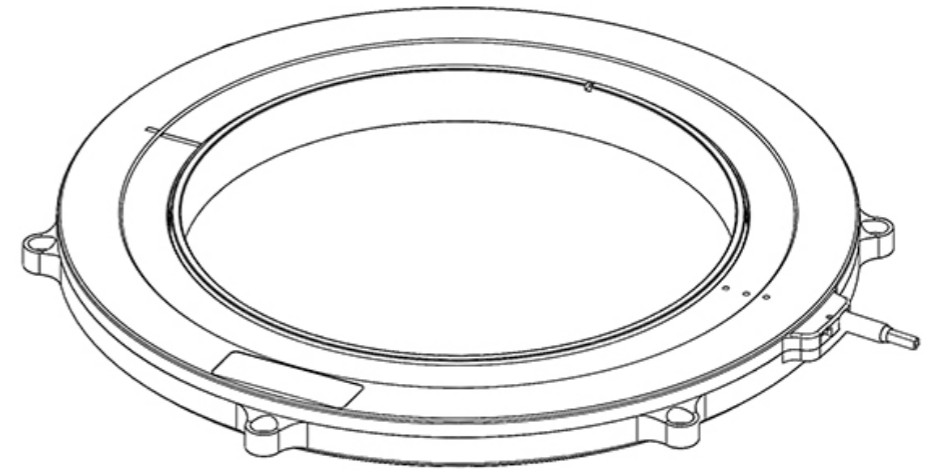
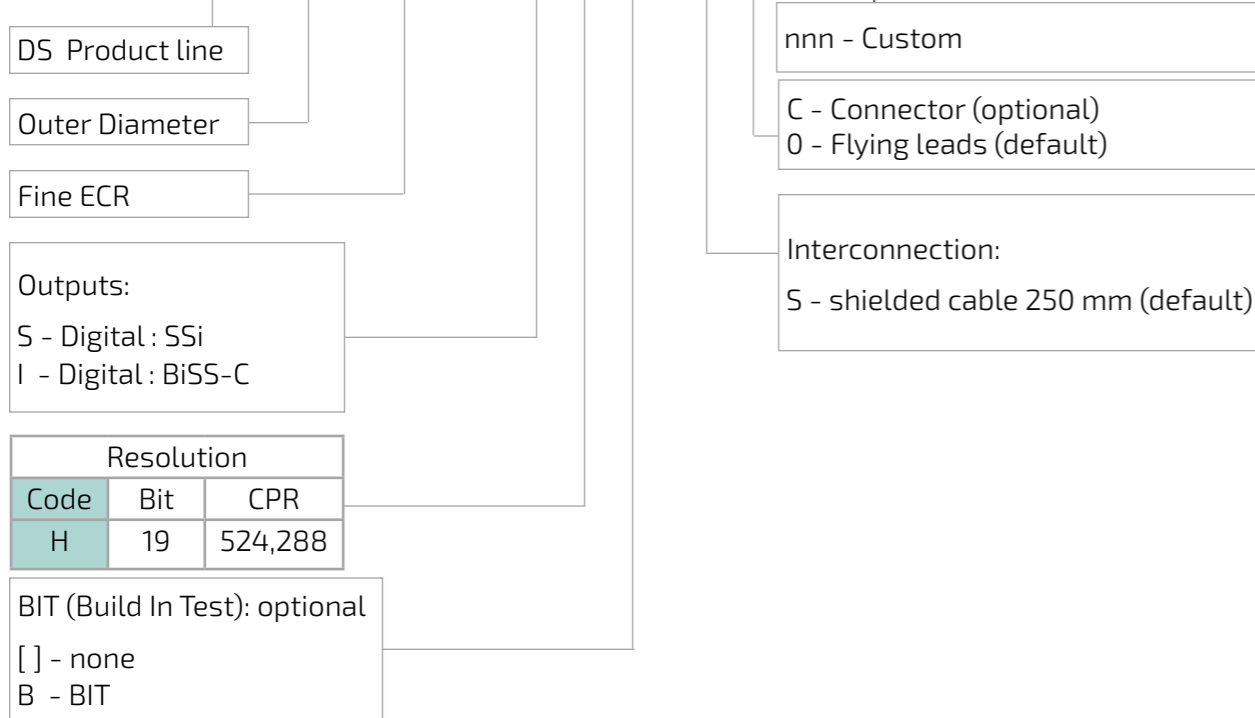

Netzer Cat No.: CB-00014

Provider: Ray-Q USA. wire CAT No: RQ213210

Cable: 30 AWG twisted pair (3) :2 (30 AWG 25/44 finned copper , 0.15 PFE to $\varnothing 0.6 \pm 0.05$ OD).

Temperature rating: -60 to +150 Deg C.

Braided shield: Thinned copper braided 95% min. coverage.

Jacket: 0.45 silicon rubber jacket $\varnothing 3.45 \pm 0.2$ OD

Pair #	Color
1	Red / Black
2	Gray / Blue
3	Green / Yellow

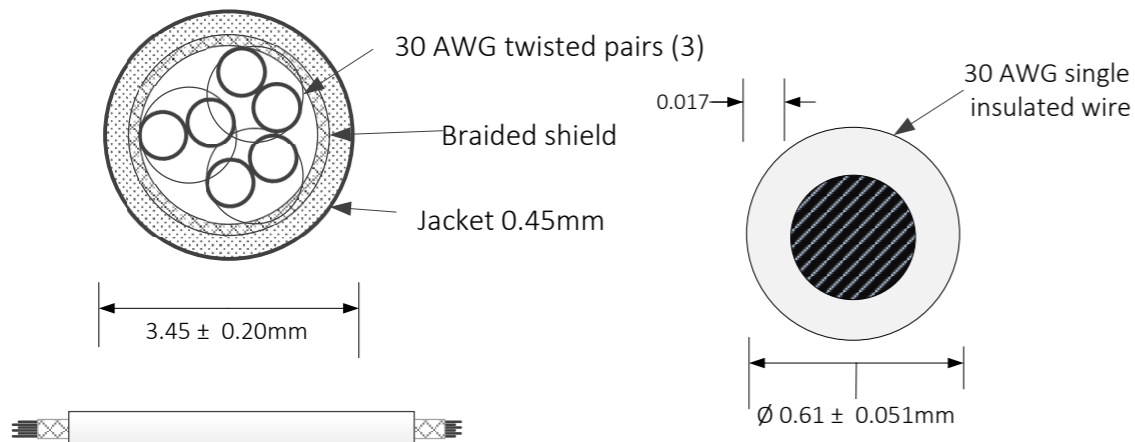

Related documents:

DS-130 User Manual : Mechanical , Electrical and calibration

Demonstration Kit:

DS-130DKIT-01: Includes ,mounted encoder on rotary jig , and RS-422 to USB converter.

DS-130-64-3SH

Absolute position, rotary Electric Encoder™

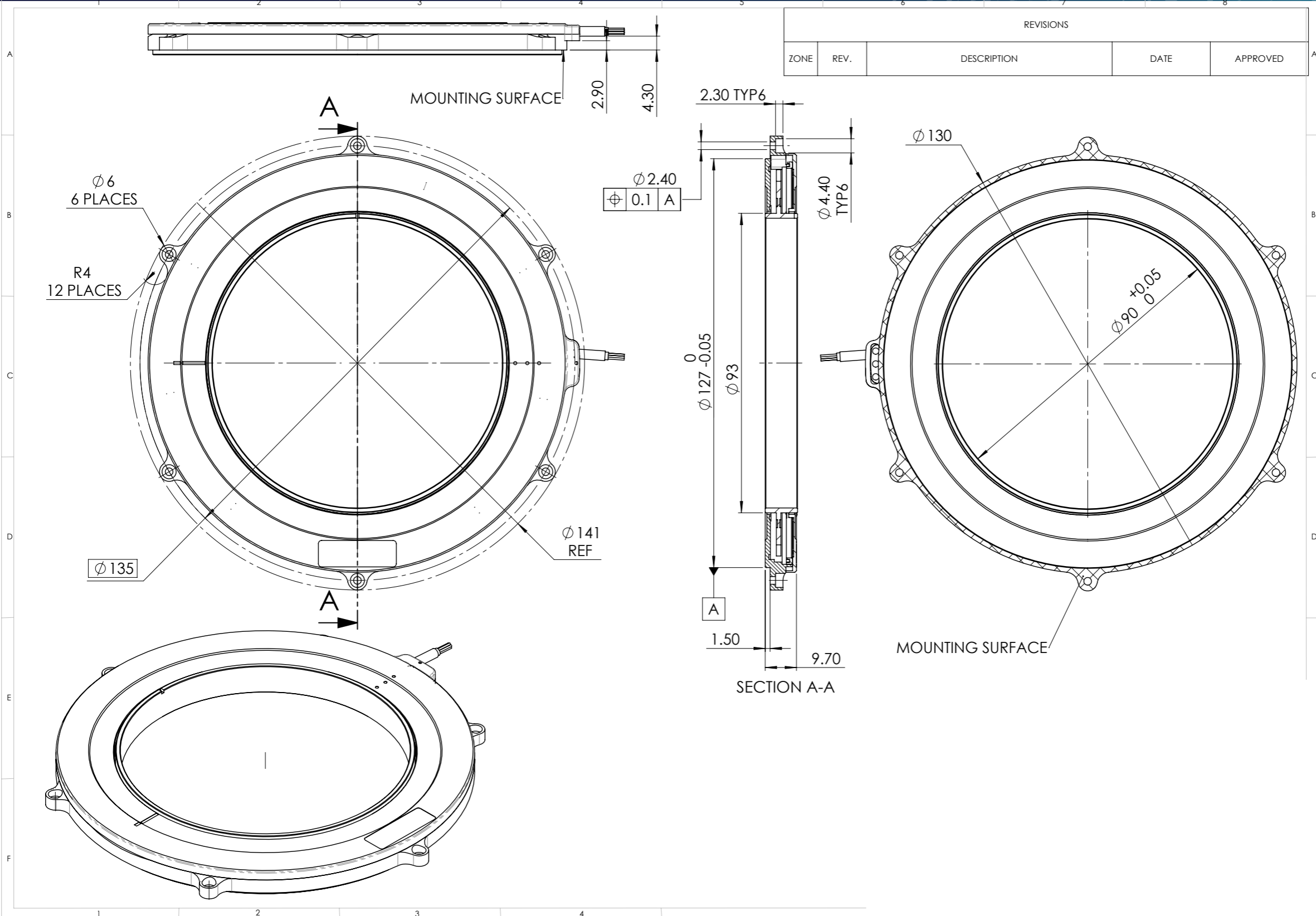

DS-130-64-3SH

Absolute position, rotary Electric Encoder™

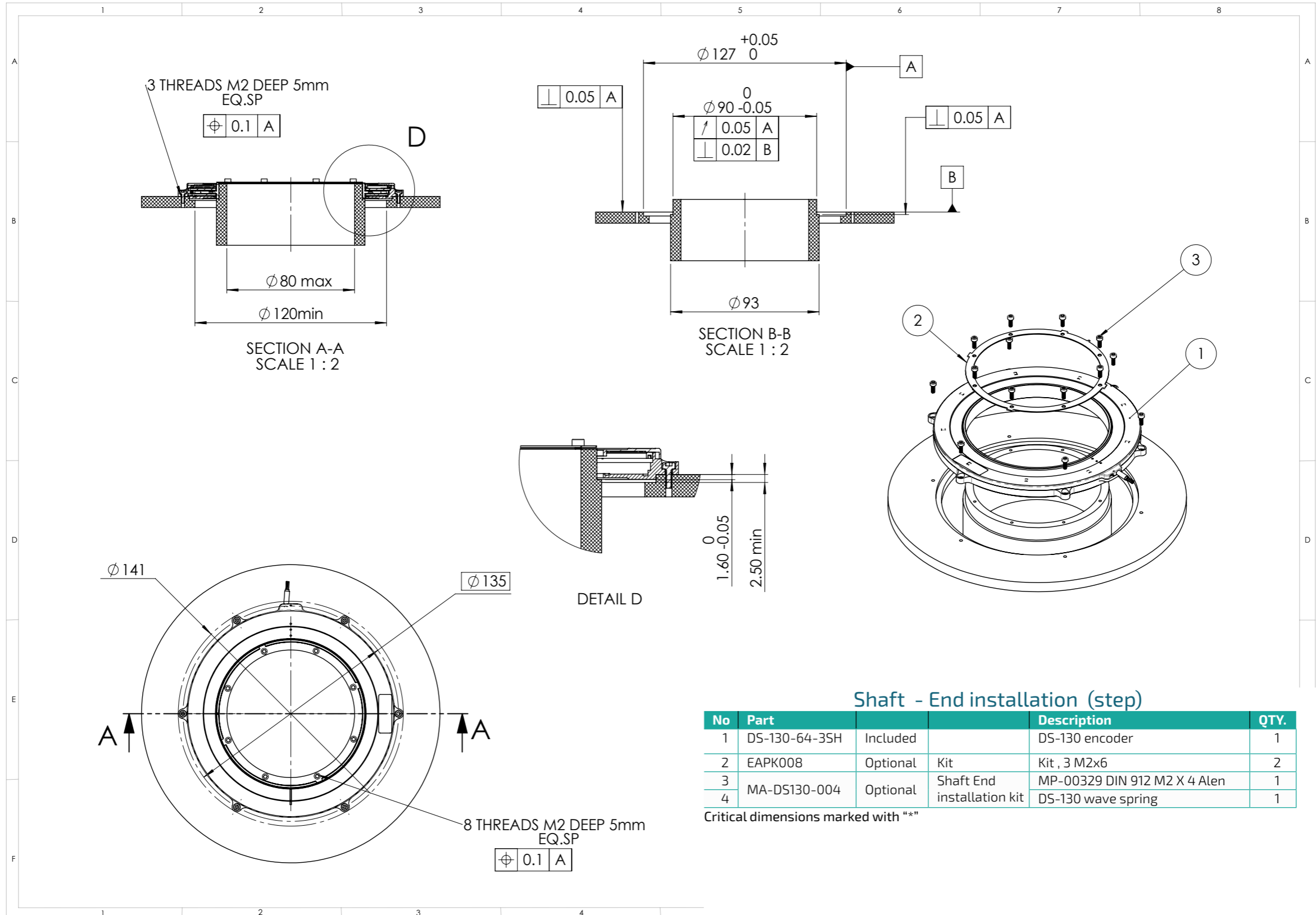

Shaft - End installation (step)

No	Part	Included	Description	QTY.
1	DS-130-64-3SH	Included	DS-130 encoder	1
2	EAPK008	Optional	Kit, 3 M2x6	2
3	MA-DS130-004	Optional	Shaft End installation kit MP-00329 DIN 912 M2 X 4 Alen	1
4			DS-130 wave spring	1

Critical dimensions marked with "**"

DS-130-64-3SH

Absolute position, rotary Electric Encoder™

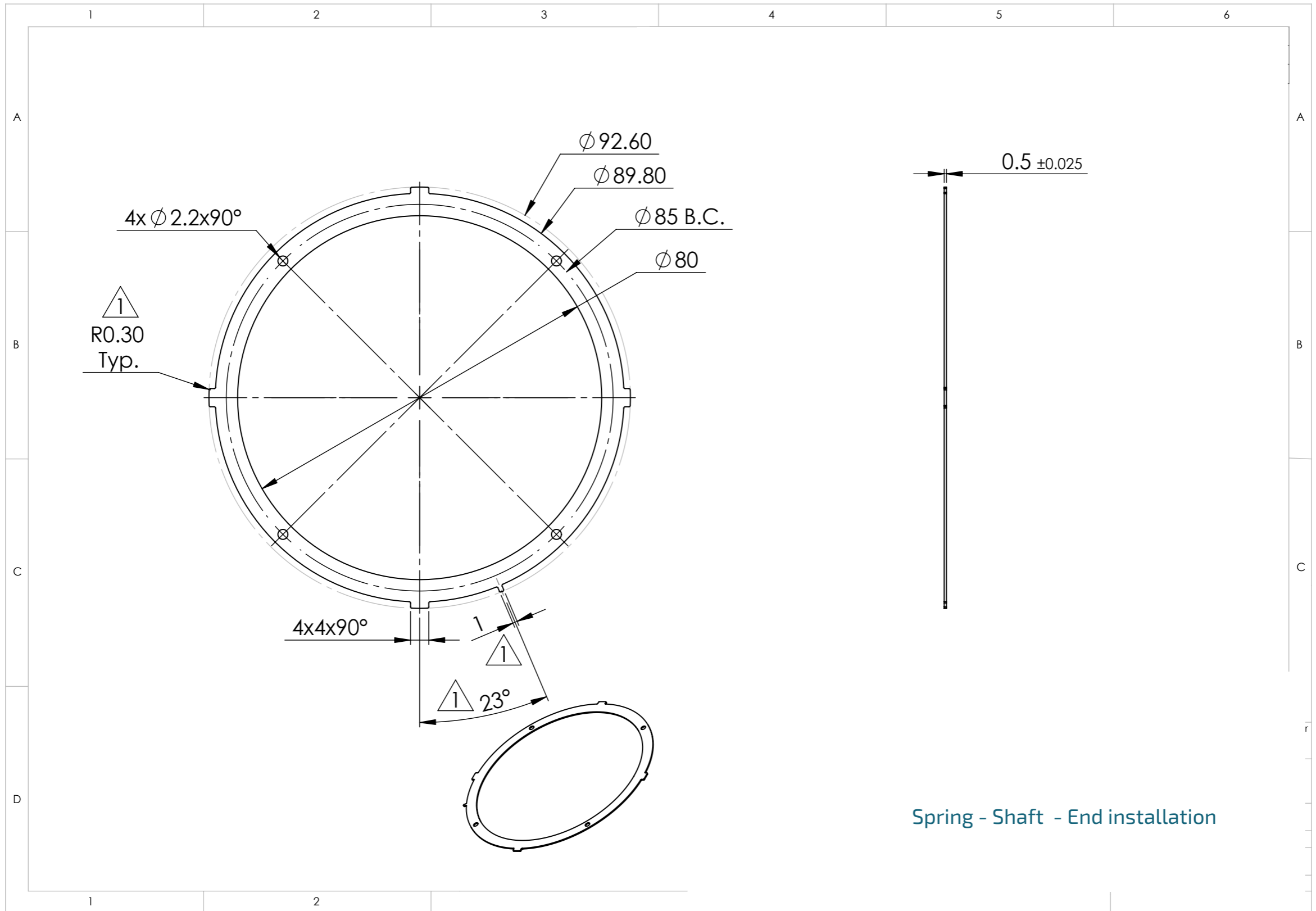

Spring - Shaft - End installation