



HIGH TORQUE-TO-WEIGHT RATIO | LIGHT-WEIGHT AND LOW-INERTIA | HIGHLY EFFICIENT
RING ARCHITECTURE | ZERO COGGING FOR PRECISION MOVEMENT | SCALABLE IN SIZE AND POWER

Data Sheet Model Number: LSI-25-10

ThinGap's LS Line includes numerous high performance brushless permanent magnet motors. The LS line targets lower speed, high precision applications such as gimbals, optics, and precision robotics. The highest torque density with high power capability and low thermal resistance.



ThinGap's LS Line of Brushless Motors

For low speed, high precision applications such as gimbals, optics, and precision robotics. Highest torque density with high power capability. Available in sizes 25mm to 267mm.

Motor Parameter Table

Continuous Parameters	Units	Value
Continuous Torque @ Max Speed	mN-m	16.300
Max Continuous Power	W	11.000
Max Continuous Speed	RPM	6370
Max Continuous Phase Current @ Max Speed	$A_{Peak-Sine}$	2.970
Required Motor Voltage @ Max Speed	V_{pk-l}	6.900
Max Continuous Coil Temperature	°C	130
Peak Parameters@Max Speed	Units	Value
Peak Torque (Duration 1)	mN-m	0.0442 (1s)
Peak Torque (Duration 2)	mN-m	0.0286 (3s)
Peak Phase Current (Duration 1)	$A_{Peak-Sine}$	7.45 (1s)
Peak Phase Current (Duration 2)	$A_{Peak-Sine}$	4.95 (3s)
Peak Power (Duration 1)	W	29 (1s)
Peak Power (Duration 2)	W	19 (3s)
Motor Constants	Units	Value
Voltage Constant	$V_{pk-l}/rad/s$	0.0070
Voltage Constant	$V_{pk-l}/kRPM$	0.755
Torque Constant	N-m/ A_{RMS}	0.0088
Motor Constants	mN-m/VW	0.0080
Electrical Parameters	Units	Value
Motor Resistance @ 20°C	Ω	0.812
Motor Resistance @ Max Temperature	Ω	1.139
Inductance	μH	7.46 \pm 16%
Number of Magnetic Poles	ea	8
Electrical Frequency @ Max Speed	Hz	425
Mechanical Parameters	Units	Value
Rotor Inertia	kg-m ²	8.211E-07
Outer Diameter	mm	25.0
Through Hole Diameter	mm	12.0
Axial Height	mm	10.1
Rotor Mass	kg	0.012
Stator Mass	kg	0.010
Part Set Mass	kg	0.022

Torque and Mechanical Speed:

Continuous rated torque of up to 16.3mNm and rated speed of up to 6370 RPM.

Motor controller recommendation:

Standard 3-Phase Controller
High frequency PWM recommended

Options available upon request:

Alternative winding design options
High temperature option
Higher speed options



Motor Data Sheet Model Number: LSI-25-10

ThinGap technology incorporates the latest electro-magnetic components where torque limits, both continuous and peak, are determined by available cooling. The charts presented develop these limits based on natural convection from the lamination stack surface with forced convection on the coil surface due to rotation of the rotor. Mounting of the laminations stack to a heat sink will further improve maximum continuous torque capacity. Contact ThinGap for application-specific requirements.

ThinGap's frameless motor part set allows it to be completely integrated resulting in the highest ratio of torque-to-volume. In this configuration, the motor's rotor and stator can be housed within the customer's assembly utilizing a common shaft and bearing system, resulting in increased coupling efficiencies, smaller system size and lower weight. **Note:** stator and rotor assembly requires tooling due the high magnetic strength of ThinGap's rotor designs.

Basic Frame Sizes Available:	
Motor Model (mm)	Cont. Torque Range (N-m)
LSI-25-10, LSI-25-16 & LSI-25-20	0.0163 to 0.0664
LSI-51-13	0.14
LSI-59-13	0.2
LSI-75-12 & LSI-75-20	0.29 to 0.66
LSI-105-33	1.5 to 1.9
LSI-130-23	1.9 to 2.2
LSI-152-29	3.6
LSI-267-32	11.5

(Custom sizes also available.)

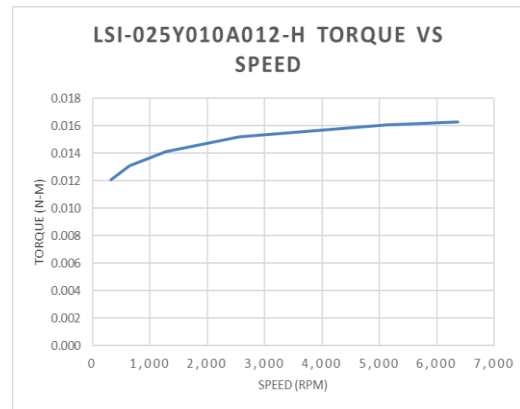

Example of typical use motor speed curve. Higher speeds possible and is dependent on the applied voltage. Top speed may be limited mechanically. Please consult factory if higher speeds are required.

Dimensions: LSI-25-10

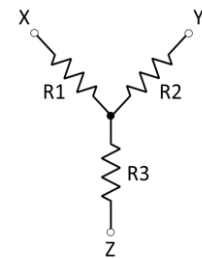
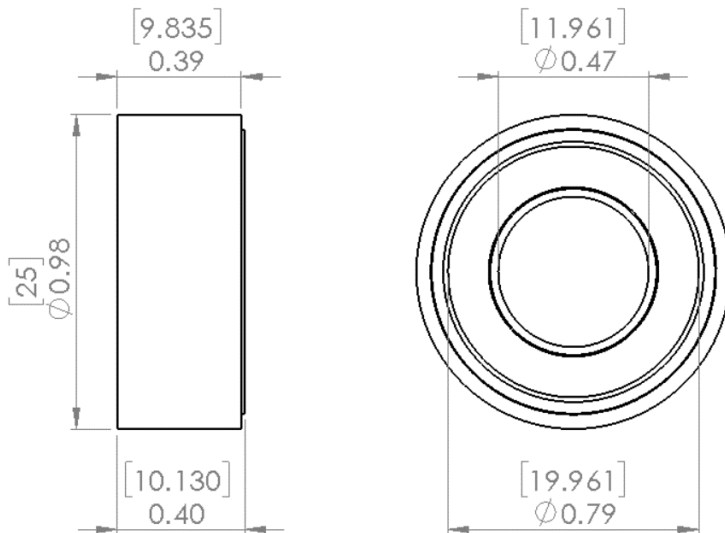

MOTOR PHASE	EXCITATION STEP						
	1	2	3	4	5	6	1
A	+	-	-	-	+	+	
B	+	+	+	-	-		
C	-	-	+	+	-		
HALL SENSORS							
H1	1	1	0	0	0	1	1
H2	0	1	1	1	0	0	0
H3	0	0	0	1	1	1	0

Dimensions in [mm] inches.

ThinGap is a leading designer and producer of US-made standard and custom motors and generators. In addition to the LS Line (presented above) for lower speed, high precision applications, the TG Line offers the highest power density motor design with high torque and inherent high-speed capability in sizes 25mm to 1 meter, and powers from mW to MW. ThinGap also develops custom and application-specific motors, such as carbon fiber-based designs and large clean output starter generators. ThinGap's high performance, zero cogging motors and generators are widely used in aerospace propulsion, hybrid power, space, medical and high-end industrial applications.