

TG231X

BRUSHLESS PERMANENT MAGNET MACHINE

PERFORMANCE

Max continuous torque	Nm	0.74
Max permissible speed	RPM	6500
Max continuous shaft power	kW	0.50
Max efficiency	%	89%
Max stator temperature	C	100
Peak Torque - 1s (3s)	Nm	2.68 (1.61)

REGION OF OPERATION

MAX CONTINUOUS
 INTERMITTENT

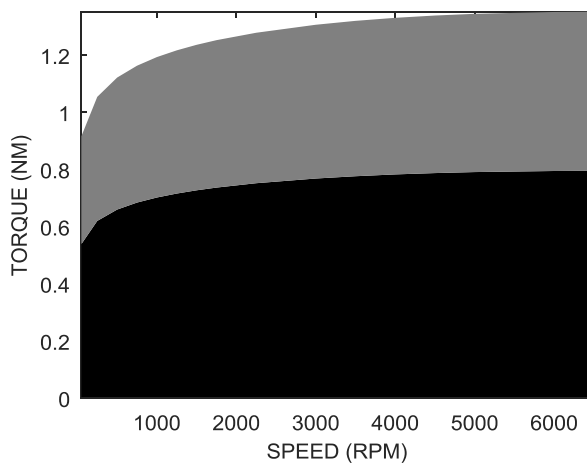

EFFICIENCY MAP

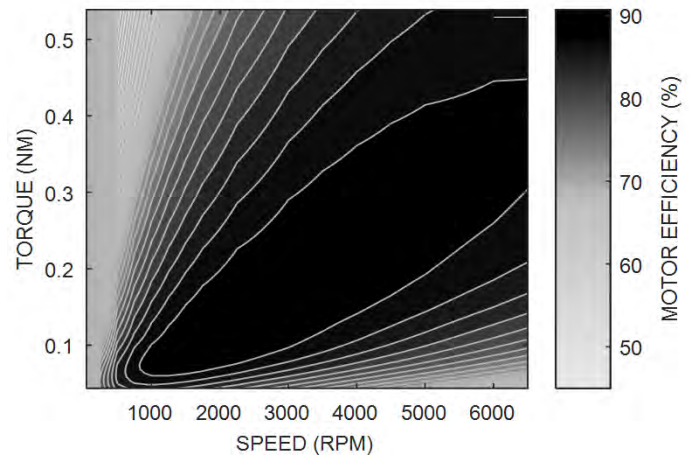

MODEL SPECIFICATIONS

		TG2310	TG2311	SYM
Winding configuration		Y	Δ	
Max continuous current	Arms	11.6	17.4	I
Voltage constant	Vpkl-I/(rad/s)	0.056	0.032	Ke
Voltage constant	Vpkl-I/kRPM	5.8	3.4	Ke
Torque constant	Nm/Arms	0.068	0.046	Kt
Motor Constant	Nm/√W	0.100	0.100	Km
Terminal resistance	Ω	0.310	0.103	R
Terminal inductance	μH	20.6	6.9	L
Motor drive voltage	Vbus	(RPM*Ke*π/30+Torque/Kt*R)*1.2		
Generator terminal voltage	Vrms	(RPM*Ke*π/30-Torque/Kt*R)/Sqrt(2)		

NOTES

- All ThinGap machines can operate as a motor or generator and can be purchased with or without frame
- When operated as a motor best performance is obtained with high frequency sinusoidal drives
- 70μH per phase of external inductance is recommended when operated with conventional <40kHz drives
- Contact ThinGap for drive compatibility and applications engineering

MODEL NUMBER

MODEL NUMBER	TG23	X	X	-XX	EXAMPLE: TG2311 - P1
Machine series	↑				
Rotor configuration		↑			
Winding configuration			↑		
Mounting option (M1/M2-Framed, P1-Frameless Part Set)				↑	

TG231X

BRUSHLESS PERMANENT MAGNET MACHINE

MECHANICAL SPECIFICATIONS

Max outer diameter	in (mm)	2.236 (57)
Through hole diameter	in (mm)	1.318 (33)
Total axial height	in (mm)	2.437 (62)
Rotor mass	lbs (kg)	0.8 (0.363)
Stator mass	lbs (kg)	1.397 (0.611)
Partset mass (rotor & stator)	lbs (kg)	0.99 (0.449)
Total motor assembly M1	lbs (kg)	1.347 (0.611)
Total motor assembly M2	lbs (kg)	1.397 (0.634)
Rotor Inertia	lbm-ft ² (kg-m ²)	4.50E-3 (1.90E-4)

MACHINE ASSEMBLY DRAWING

SHOWN WITH M1 MOUNTING OPTION

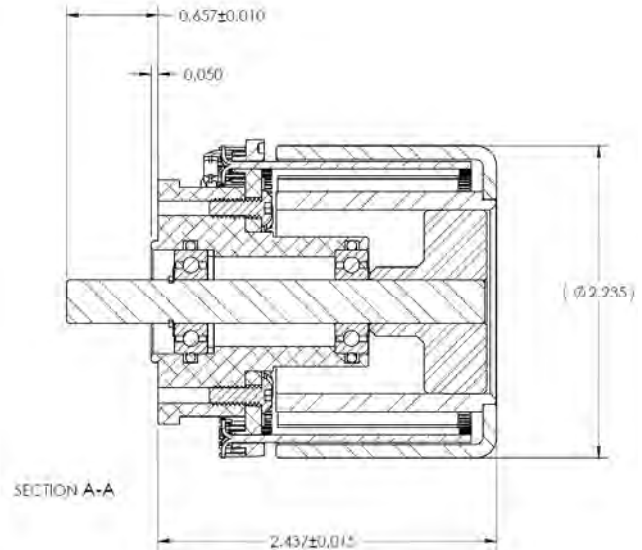
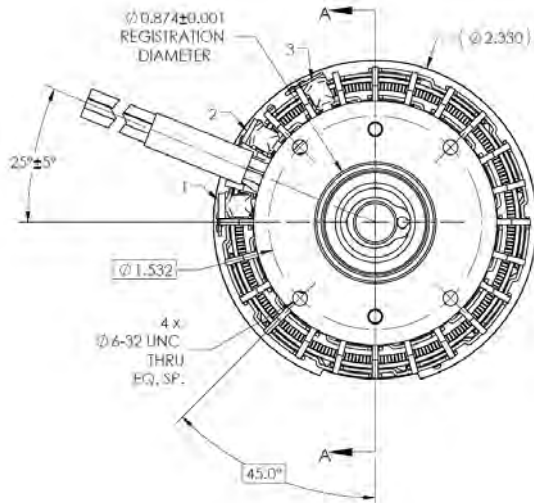

Hall Sensor Lead Identification			Phase Lead Identification			Motor Excitation (Trapezoidal Commutation)							
Lead #	Color	Description	Lead #	Color	Description	Phase	Excitation Step						
							1	2	3	4	5	6	1
1	YEL	V+	1	GRN	PHASE A	A	+	-	-	-	+	+	
2	GRY	COM -	2	BLK	PHASE B		-	+	+	-	-	-	
3	BRN	HALL 1	3	RED	PHASE C	C	-	-	+	+	-	-	
4	ORN	HALL 2					-	-	-	-			
5	BLU	HALL 3											