

TG303X

BRUSHLESS PERMANENT MAGNET MACHINE

PERFORMANCE

Max continuous torque	Nm	0.14
Max permissible speed	RPM	30600
Max continuous shaft power	W	103
Max efficiency	%	80%
Max stator temperature	C	100
Peak Torque - 1s (3s)	Nm	0.41 (0.25)

REGION OF OPERATION

MAX CONTINUOUS
 INTERMITTENT

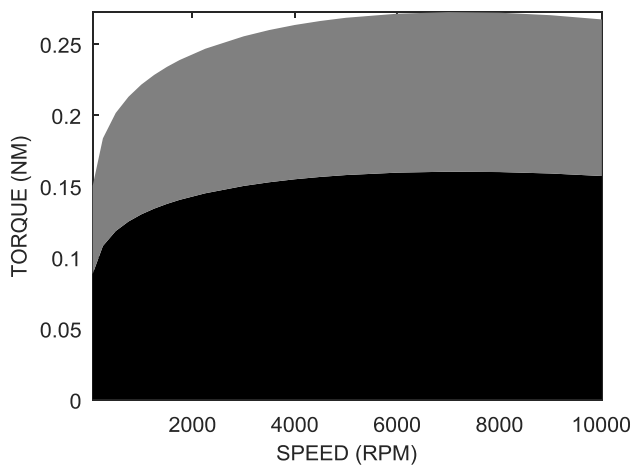

EFFICIENCY MAP

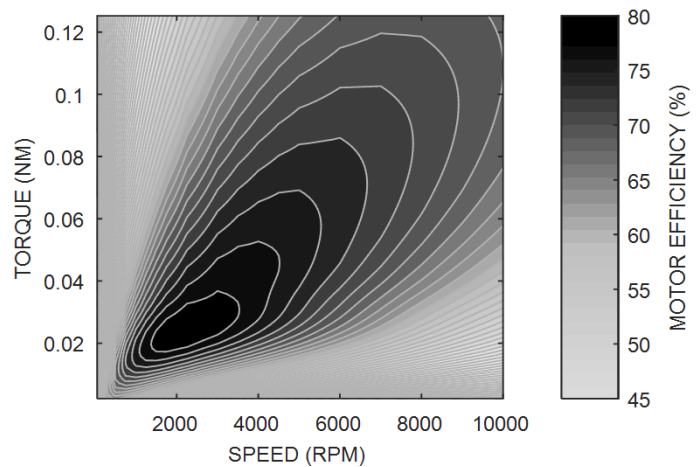

MODEL SPECIFICATIONS

		TG3030	TG3031	TG3032	TG3033	SYM
Winding configuration		Series Y	Series Δ	Parallel Y	Parallel Δ	
Max continuous current	Arms	3.2	4.8	6.5	9.7	I
Voltage constant	Vpkl-I/(rad/s)	0.040	0.023	0.020	0.012	Ke
Voltage constant	Vpkl-I/kRPM	4.2	2.4	2.1	1.2	Ke
Torque constant	Nm/Arms	0.049	0.033	0.025	0.016	Kt
Motor Constant	Nm/√W	0.028	0.028	0.028	0.028	Km
Terminal resistance	Ω	2.027	0.676	0.507	0.169	R
Terminal inductance	μH	34.8	11.6	8.7	2.9	L
Motor drive voltage	Vbus	(RPM*Kv*π/30+Torque/Kt*R)*1.2				
Generator terminal voltage	Vrms	(RPM*Kv*π/30-Torque/Kt*R)/Sqrt(2)				

NOTES

- All ThinGap machines can operate as a motor or generator
- When operated as a motor best performance is obtained with high frequency sinusoidal drives
- 70μH per phase of external inductance is recommended when operated with conventional drives
- Consult ThinGap engineering for drive compatibility and applications engineering

MODEL NUMBER

	TG30	X	X	-	X010	EXAMPLE: TG3032 - P010
Machine series	↑					
Rotor configuration		↑				
Winding configuration			↑			
Mounting option (M-Framed, P-Frameless Part Set)				↑		

TG303X

BRUSHLESS PERMANENT MAGNET MACHINE

MECHANICAL SPECIFICATIONS

Max outer diameter	in (mm)	2.808 (71)
Through hole diameter	in (mm)	2.424 (62)
Total axial height	in (mm)	0.647 (16)
Rotor mass	lbs (g)	0.115 (52)
Stator mass	lbs (g)	0.139 (63)
Partset mass (rotor & stator)	lbs (g)	0.254 (115)
Total motor assembly mass	lbs (g)	0.38 (171)
Rotor Inertia	lbm-ft ² (kg-m ²)	1.22E-3 (5.14E-5)

MACHINE ASSEMBLY DRAWING

M010 MOUNT

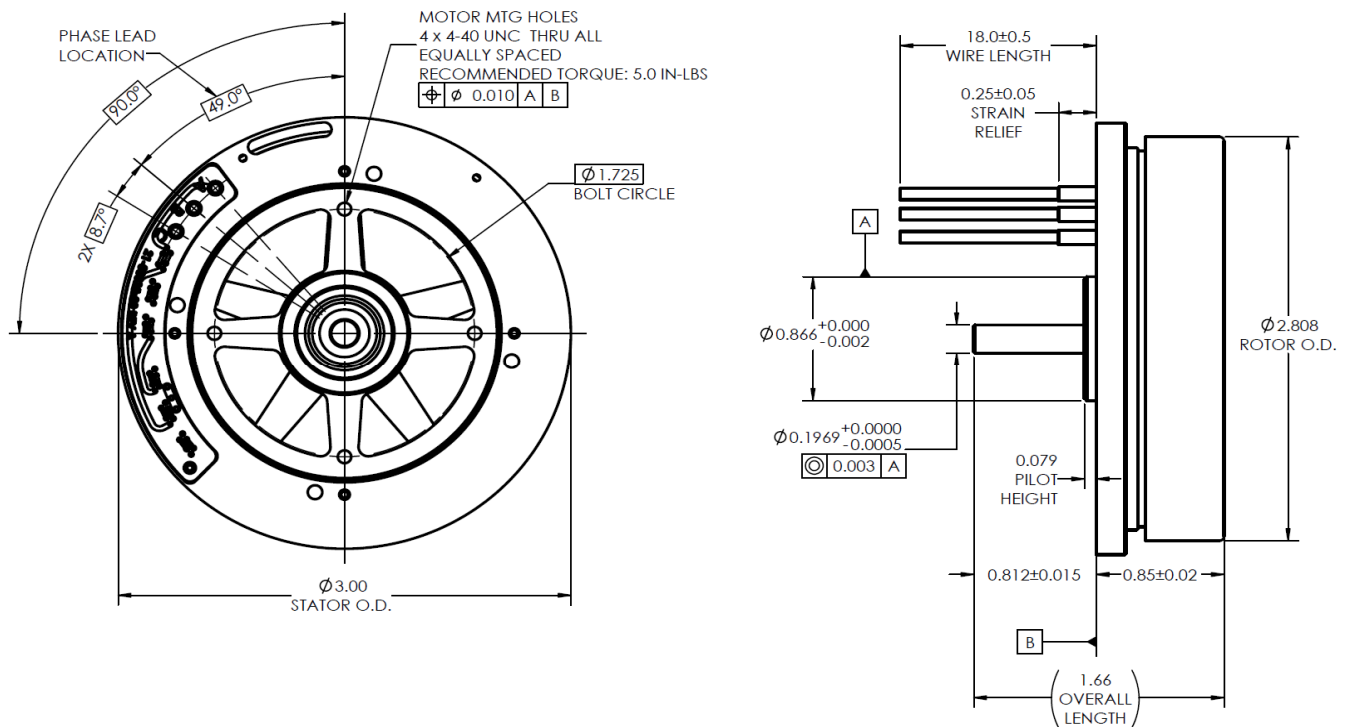

TG303X Phase Lead Identification			Motor Excitation (Trapezoidal Commutation)						
Lead #	Color	Description	Phase	Excitation Step					
				1	GRN	PHASE A	A	+	-
2	BLK	PHASE B	B		+	+	-	-	
3	RED	PHASE C	C	-	-		+	+	