

# TG515X

## BRUSHLESS PERMANENT MAGNET MACHINE

### PERFORMANCE

Max continuous torque	Nm	3.57
Max permissible speed	RPM	10300
Max continuous shaft power	kW	2.99
Max efficiency	%	93%
Max stator temperature	C	120
Peak Torque - 1s (3s)	Nm	11.52 (6.88)

### REGION OF OPERATION

MAX CONTINUOUS
  INTERMITTENT

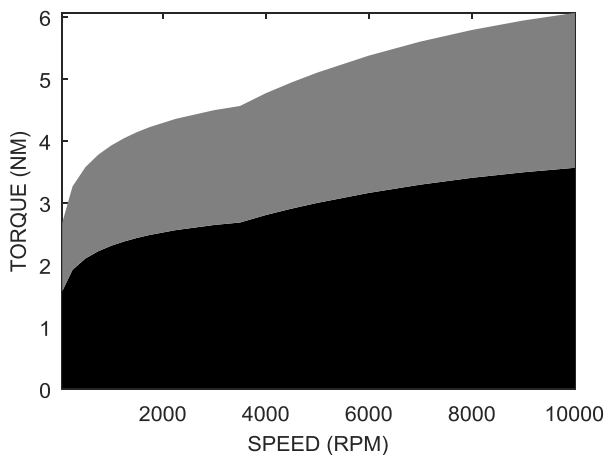

### EFFICIENCY MAP

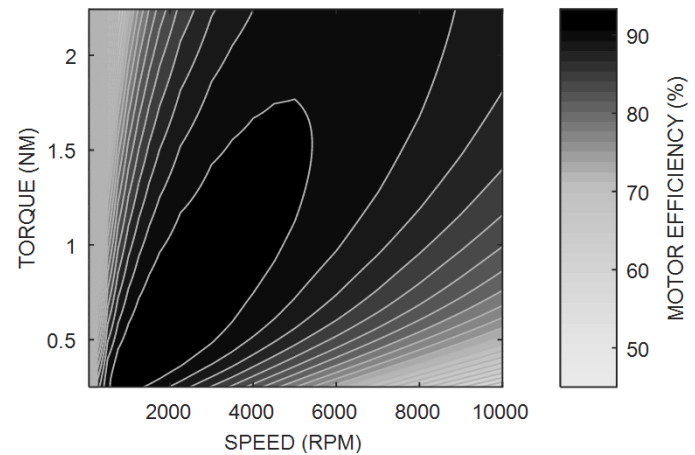

### MODEL SPECIFICATIONS

		TG5150	TG5151	TG5152	TG5153	SYM
Winding configuration		Series Y	Series Δ	Parallel Y	Parallel Δ	I
Max continuous current	Arms	16.6	24.8	33.1	49.7	I
Voltage constant	Vpkl-I/(rad/s)	0.186	0.108	0.093	0.054	Ke
Voltage constant	Vpkl-I/kRPM	19.5	11.3	9.8	5.6	Ke
Torque constant	Nm/Arms	0.228	0.152	0.114	0.076	Kt
Motor Constant	Nm/√W	0.289	0.289	0.289	0.289	Km
Terminal resistance	Ω	0.417	0.139	0.104	0.035	R
Terminal inductance	μH	19.0	6.3	4.8	1.6	L
Motor drive voltage	Vbus	(RPM*Kv*π/30+Torque/Kt*R)*1.2				
Generator terminal voltage	Vrms					(RPM*Kv*π/30-Torque/Kt*R)/Sqrt(2)

### NOTES

- All ThinGap machines can operate as a motor or generator and can be purchased with or without frame
- When operated as a motor best performance is obtained with high frequency sinusoidal drives
- 70μH per phase of external inductance is recommended when operated with conventional <40kHz drives
- Contact ThinGap for drive compatibility and applications engineering

### MODEL NUMBER

Machine series	TG51	X	X	-	X010	EXAMPLE: TG5152 - P010
Machine series	↑					
Rotor configuration		↑				
Winding configuration			↑			
Mounting option (M-Framed, P-Frameless Part Set)				↑		

# TG515X

## BRUSHLESS PERMANENT MAGNET MACHINE

### MECHANICAL SPECIFICATIONS

Max outer diameter	in (mm)	5.45 (138)
Through hole diameter	in (mm)	4.566 (116)
Total axial height	in (mm)	1.184 (30)
Rotor mass	lbs (kg)	1.059 (0.48)
Stator mass	lbs (kg)	0.293 (0.133)
Partset mass (rotor & stator)	lbs (kg)	1.352 (0.613)
Total motor assembly mass	lbs (kg)	2 (0.907)
Rotor Inertia	lbm-ft <sup>2</sup> (kg-m <sup>2</sup> )	4.81E-2 (2.03E-3)

### MACHINE ASSEMBLY DRAWING

### SHOWN WITH M010 MOUNTING OPTION

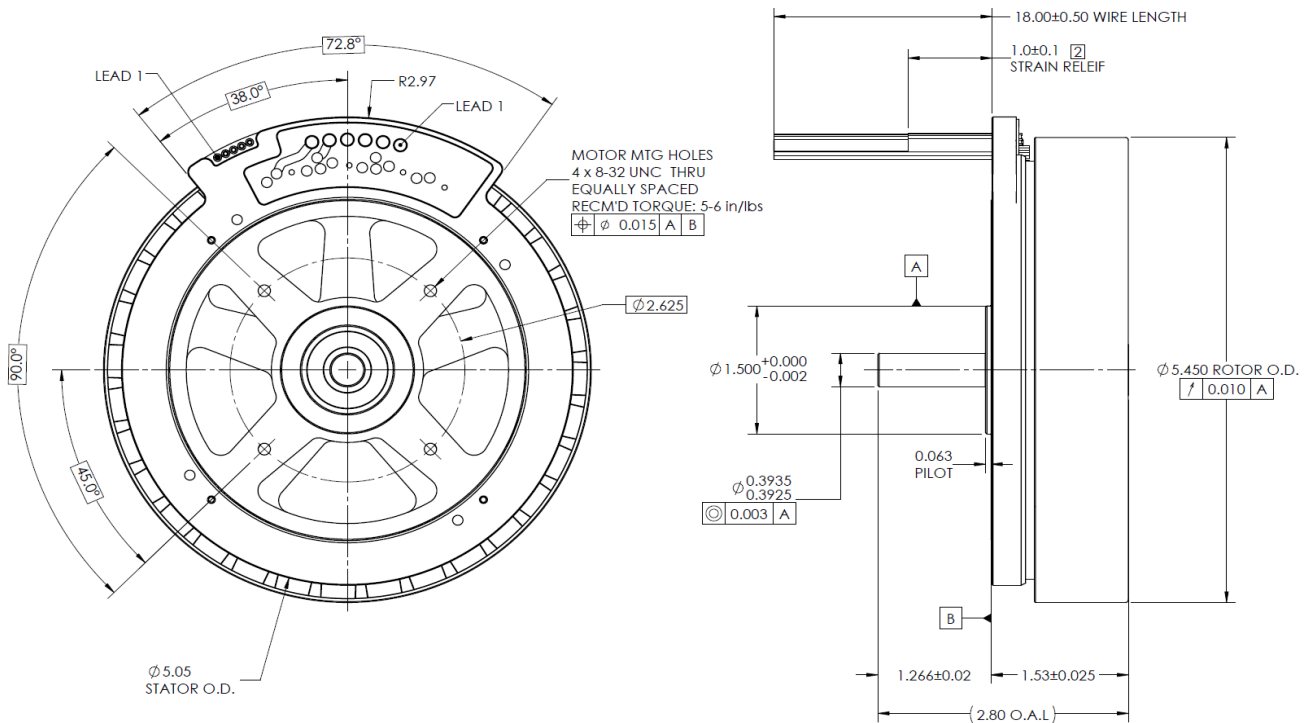

### POWER CONNECTION

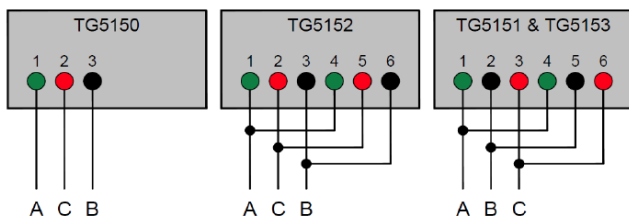

MOTOR EXCITATION		Hall Sensor Lead Identification							
PHASE	EXCITATION STEP						Lead #	Color	Description
	1	2	3	4	5	6	1		
A	+	-	-	-	+	+	1	YEL	V+
B		+	+	-	-		2	GRY	COM -
C	-	-		+	+	-	3	BRN	HALL A
							4	BLU	HALL B
							5	ORN	HALL C