



The DS-16 is a member of the DS series of Electric Encoders™ a product line based on Netzer Precision Motion Sensor proprietary technology. EE products are characterized by features that enable unparalleled performance:

- Low profile (8 mm)
- Hollow, floating shaft
- No bearings or other contact elements
- High resolution and unparalleled precision
- High tolerance to temperature extremes, shock, moisture, EMI, RFI and magnetic fields
- Very low weight
- Holistic signal generation
- Digital interfaces for absolute position

The Electric Encoder™ is unique in being holistic, i.e., its output reading is the averaged outcome of the whole area of the rotor. This feature makes the Electric Encoder™ forgiving to mounting tolerances, mechanical wander etc.

The absence of components such as ball bearings, flexible couplers, glass disc, light sources and detectors, along with very low power consumption makes the Electric Encoder™ virtually failure free.

The internally shielded, DC operated Electric Encoder™ includes an electric field generator, a field receiver, a sinusoidal shaped dielectric rotor, and processing electronics.

The output of Electric Encoder™ is a digital serial with absolute position single turn. The combination of precision, low profile, low weight and high reliability have made Netzer Precision encoders particularly suitable to a wide variety of industrial automation applications.

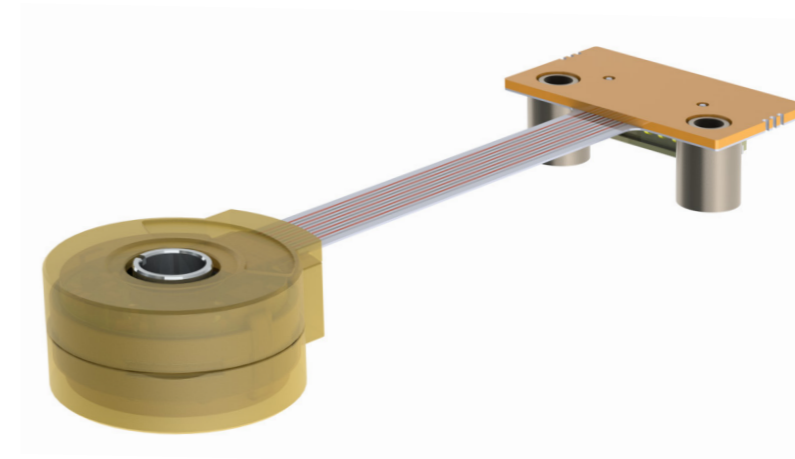

General

Angular resolution	16 bits; 65,536 CPR
Maximum tested static error	≤ 0.035°
Maximum operational speed	4,000 rpm
Measurement range	Single turn
Build In Test - BIT	Optional

Mechanical

Allowable mounting eccentricity	±0.1 mm
Allowable rotor axial motion	±0.1 mm
Rotor inertia	11 gr · mm ²
Total weight	3.1 gr (with connector)
Outer Ø / Inner Ø / Height	16 / 4 / 8 mm
Material (stator, rotor)	Ultem™ polymer

Electrical

Supply voltage	5V ± 10%
Current consumption	80 mA
Interconnection	Flex cable, Connector
Cable length	1,500 mm MAX

Environmental

EMC	IEC 6100-6-2, IEC 6100-6-4
Operating temperature range	-40°C to +85°C
Storage temperature	-50°C to +100°C
Relative humidity	98% Non condensing
Shock endurance	Operating: 100 g for 6 ms
Vibration endurance	20 g 10 – 2000 Hz
Protection	IP 40

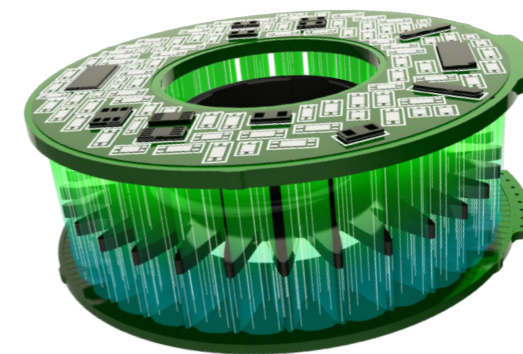



Digital SSI Interface

Synchronous Serial Interface (SSI) is a point to point serial interface standard between a master (e.g. controller) and a slave (e.g. sensor) for digital data transmission.

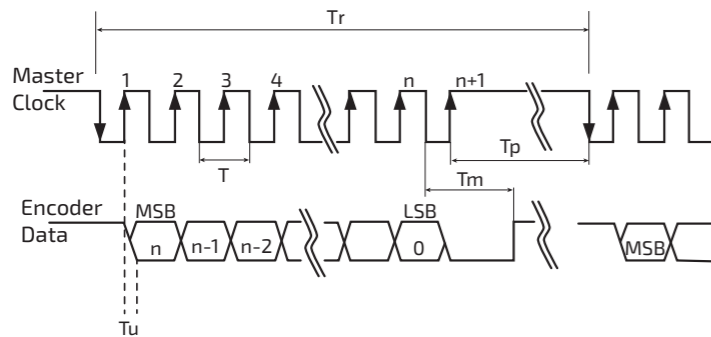

SSI / BiSS output signal parameters

Output code	Binary
Serial output	Differential RS-422
Clock	Differential RS-422
Clock Frequency	0.1 ÷ 5.0 MHz
Position update rate	35 kHz (Optional - up to 375 KHz)

SSI / BiSS interface - connector DF13-6P-1.25H

Clock +	1	Clock
Clock -	2	
Data -	3	Data
Data +	4	
GND	5	Ground
+5V	6	Power supply

	Description	Recommendations
n	Total number of data bits	12 - 17
T	Clock period	
f= 1/T	Clock frequency	0.1 ÷ 5.0 MHz
Tu	Bit update time	200 nsec
Tp	Pause time	26 - ∞ μsec
Tm	Monoflop time	>25 μsec
Tr	Time between 2 adjacent requests	Tr > n*T+26 μsec
fr=1/Tr	Data request frequency	

Software tools: (SSI / BiSS-C)



Advanced calibration and monitoring options are available by using the factory supplied [Electric Encoder Explorer software](#). This facilitates proper mechanical mounting, offsets calibration and advanced signal monitoring.

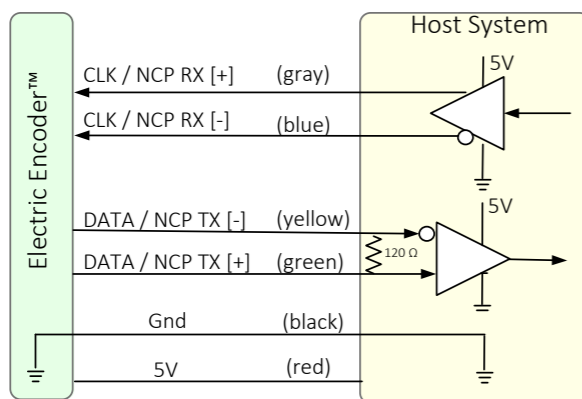
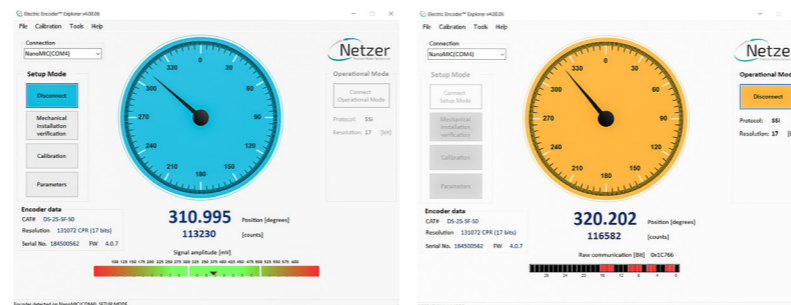

Digital BiSS-C Interface

BiSS-C Interface is unidirectional serial synchronous protocol for digital data transmission where the Encoder acts as "slave" transmits data according to "Master" clock. The BiSS protocol is designed in B mode and C mode (continuous mode). The BiSS-C interface as the SSI is based on RS-422 standards.

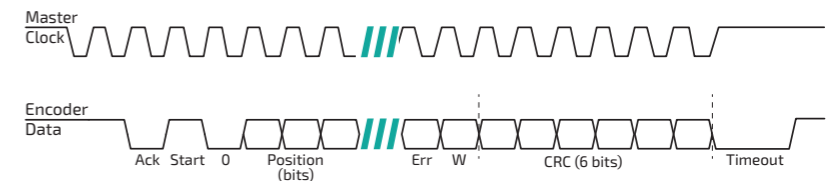

Bit #		Description	Default	Length
27	Ack	Period during which the encoder calculates the absolute position, one clock cycle	0	1/clock
26	Start	Encoder signal for "start" data transmit	1	1 bit
25	"0"	"start" bit follower	0	1 bit
8...24	AP	Absolute Position encoder data		
7	Error	Error (amplitude levels)	1	1 bit
6	Warn.	Warning (non active)	1	1 bit
0...5	CRC	The CRC polynomial for position, error and warning data is: $x^6 + x^1 + x^0$. It is transmitted MSB first and inverted. The start bit and "0" bit are omitted from the CRC calculation.		6 bits
	Timeout	Elapse between the sequential "start" request cycle's.		25 μs

Ordering Code

DS - 16 - S E - FC

DS Product line

Outer Diameter

Output

S SSi

I BiSS

Resolution

Code	Bit	CPR
E	16	65,536

BIT (Build In Test): optional

[] None

B BIT

Interconnection

FC Connector DF13-6P-1.25H

F0 Without Connector

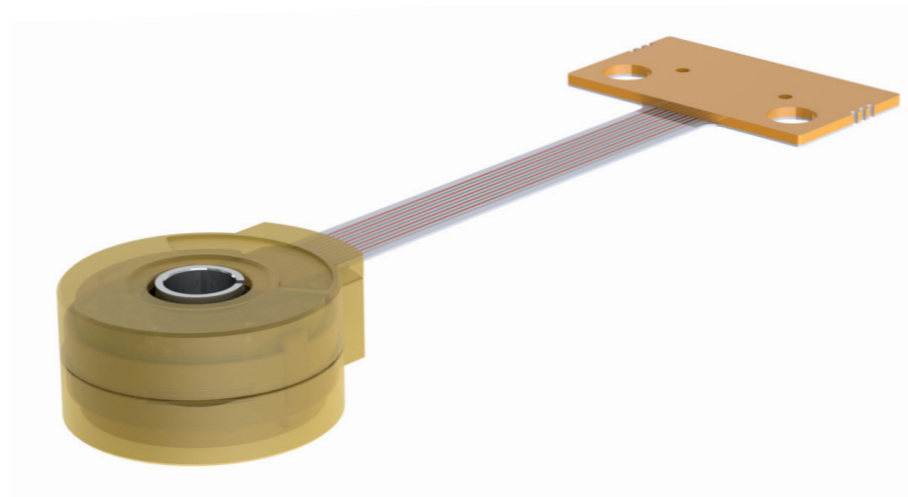
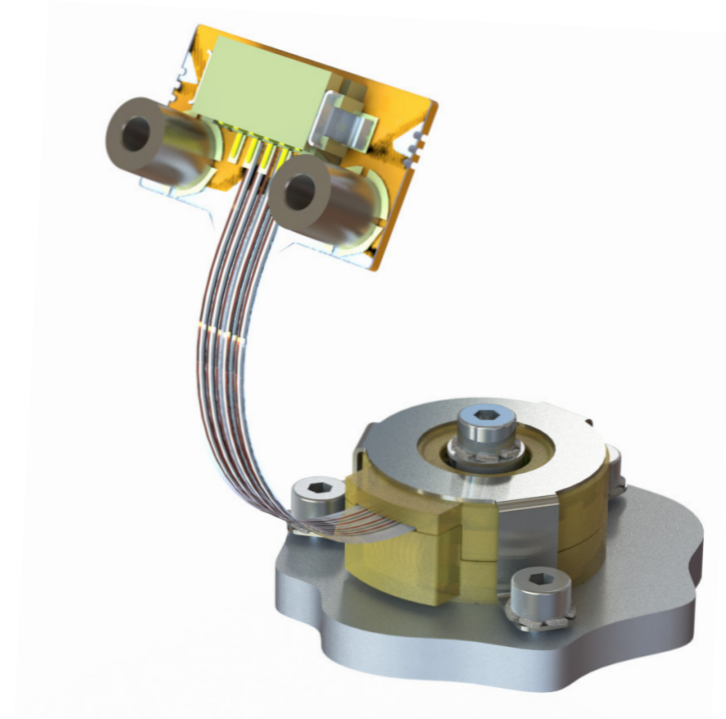

Related documents

DS-16 User Manual : Mechanical , Electrical and calibration setup.

Optional Accessories

Demonstration Kit

- DKIT-DS-16-SE-FC - with SSi interface
- DKIT-DS-16-IE-FC - with BiSS interface
Includes, mounted encoder on rotary jig, and RS-422 to USB converter.
- RJ-16: DS-16 rotary jig

ICD, DS-16 with connector

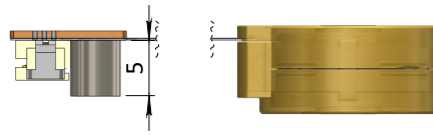

Bus bending radius 2 mm min.

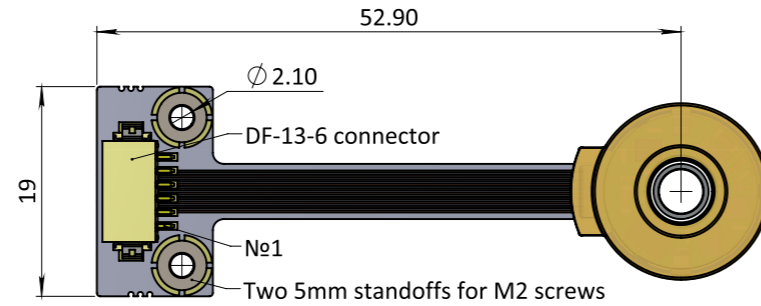

Encoder with flexible connector bus (bottom view).

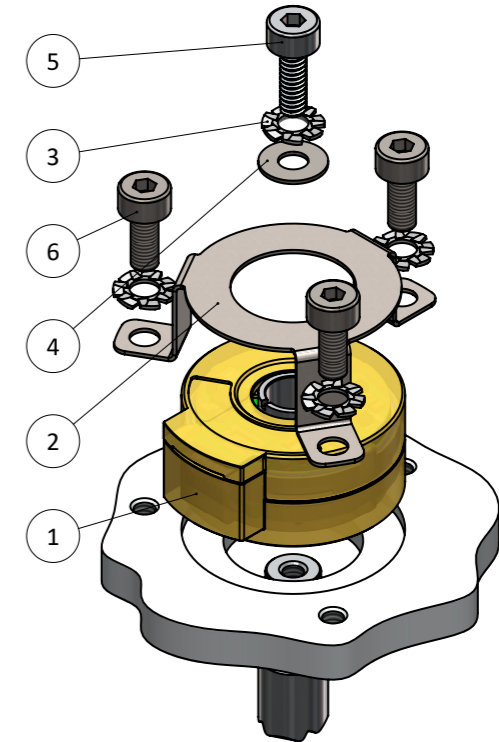
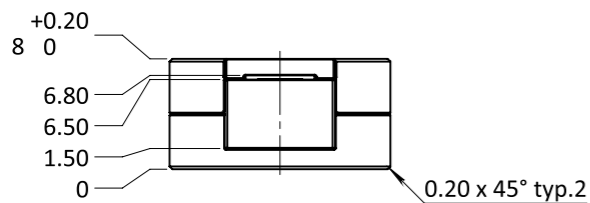
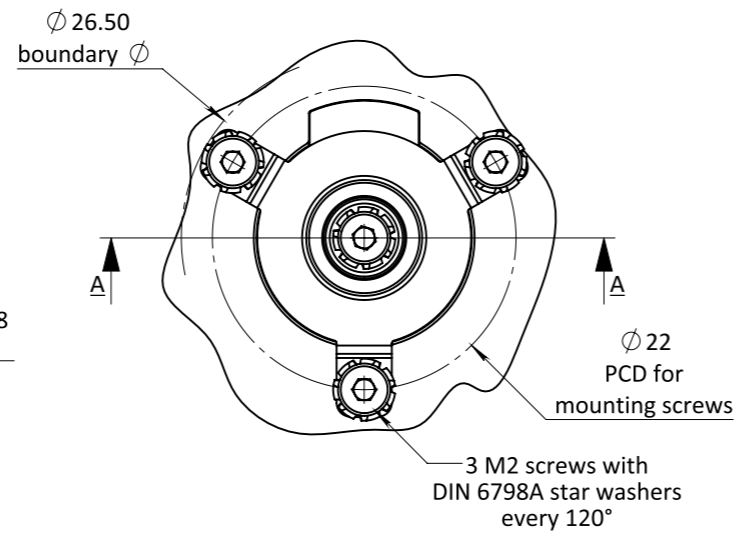
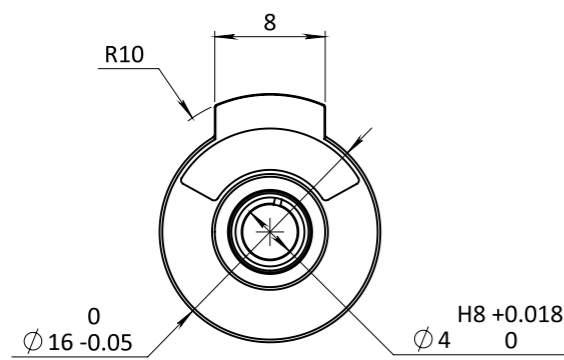
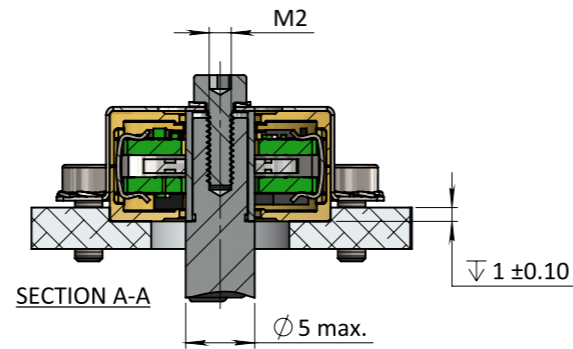
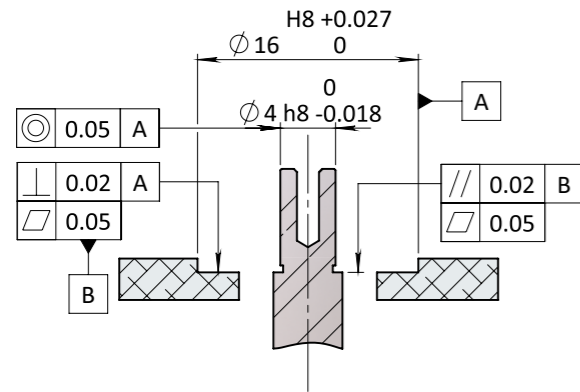

No	Part	Description	QTY.	Torque
1	DS-16-SE-FC	Included DS-16 encoder with connector	1	-
2	MP-03649	Included DS-16 Mounting bracket	1	-
3	MP-036491	Included Star washer, DIN 6798A, M2	4	-
4	MP-01102	Included Flat washer 125 M2 - ID 2.2	1	-
5	PP00247	Included Hex socket screw, DIN 912, M2x6	1	0.3 Nm
6	MP-01209	Included Hex socket screw, DIN 912, M2x5	3	0.2 Nm

Critical dimensions marked with "*"

WARNING



Do not use Loctite or other glues containing Cyanoacrylate. We recommend to use 3M glue - Scotch-Weld™ Epoxy Adhesive EC-2216 B/A.

ICD, DS-16 without connector

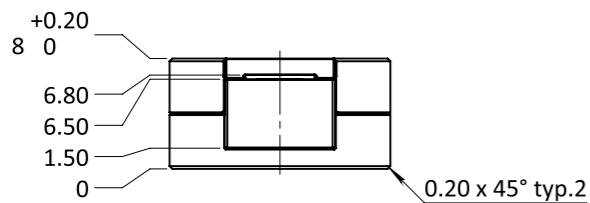
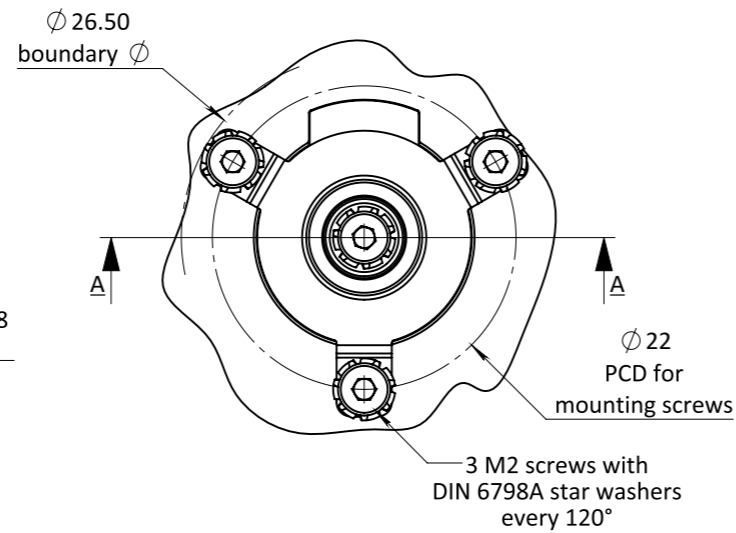
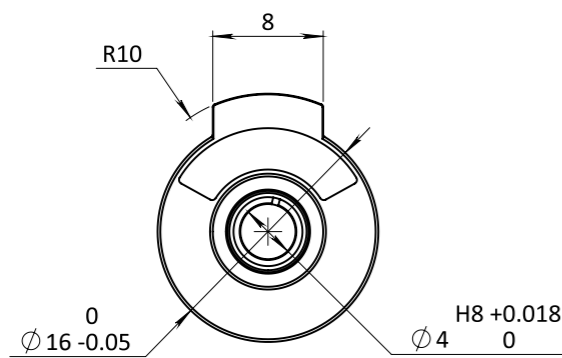
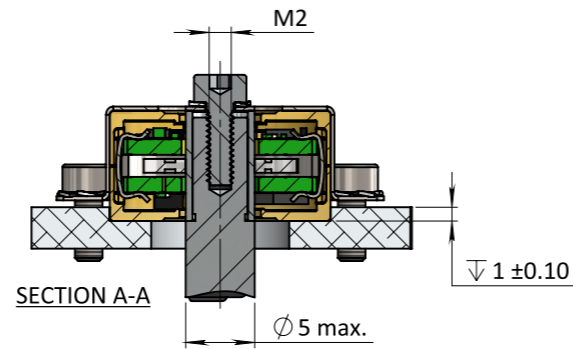
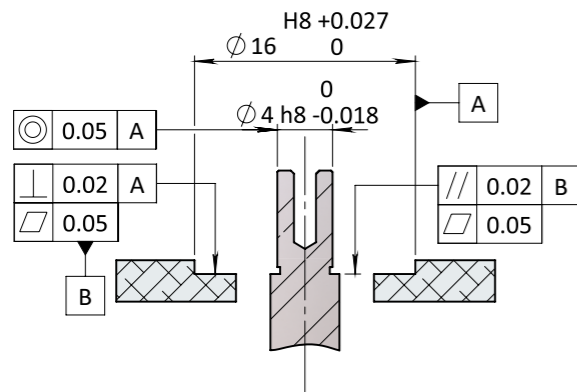
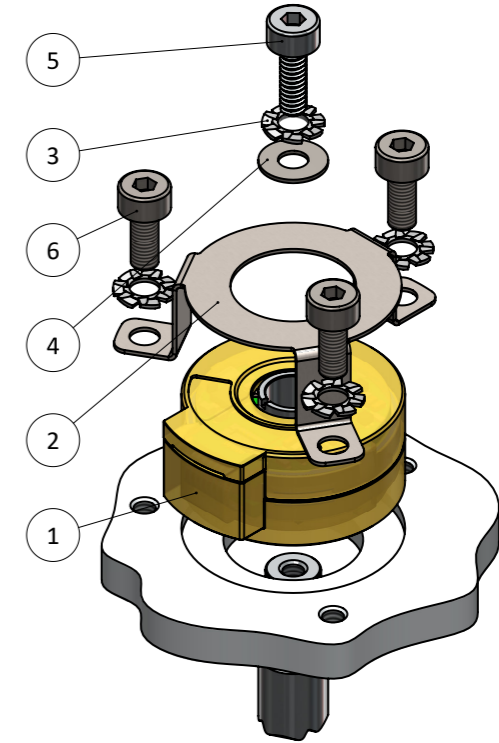
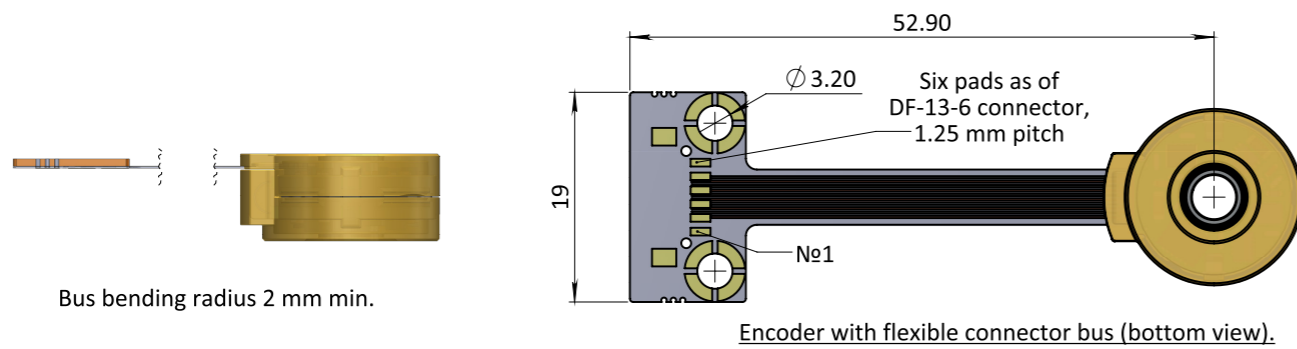

No	Part	Description	QTY.	Torque
1	DS-16-SE-FC	Included DS-16 encoder with connector	1	-
2	MP-03649	Included DS-16 Mounting bracket	1	-
3	MP-036491	Included Star washer, DIN 6798A, M2	4	-
4	MP-01102	Included Flat washer 125 M2 - ID 2.2	1	-
5	PP00247	Included Hex socket screw, DIN 912, M2x6	1	0.3 Nm
6	MP-01209	Included Hex socket screw, DIN 912, M2x5	3	0.2 Nm

Critical dimensions marked with "**"

WARNING



Do not use Loctite or other glues containing Cyanoacrylate. We recommend to use 3M glue - Scotch-Weld™ Epoxy Adhesive EC-2216 B/A.