

The VLP-60 is a member of the VLP series of Electric Encoders™ a product line based on Netzer Precision Position Sensor proprietary technology. EE products are characterized by features that enable unparalleled performance:

- Low profile (<6 mm)
- Hollow shaft (Stator / Rotor)
- No bearings or other contact elements
- High resolution and unparalleled precision
- High tolerance to temperature extremes, shock, moisture, EMI, RFI and magnetic fields
- Very low weight
- Holistic signal generation
- Digital interfaces for absolute position

General

Angular resolution	18-20 bit
Maximum tested static error	±0.015°
Extended accuracy static error	±0.010°
Maximum operational speed	4,000 rpm
Measurement range	Single turn, unlimited
Rotation direction	Adjustable CW/CCW*

* Default same direction from bottom side of the encoder

Mechanical

Allowable mounting eccentricity	±0.1 mm
Allowable axial mounting tolerance	±0.1 mm
Rotor inertia	1,930 gr · mm ²
Total weight	16 gr
Outer Ø /Inner Ø/ Height	60 / 25/ 6 mm
Material (stator, rotor)	FR4
Nominal air gap (stator, rotor)	0.6 mm

The holistic structure of the Electric Encoder™ makes it unique: Its output reading is the averaged outcome of the entire area of the rotor. This feature allows the EE a tolerant mechanical mounting and to deliver outstanding precision.

Due to the absence of components such as ball bearings, flexible couplers, glass discs, light sources and detectors along with very low power consumption enables the EE to deliver virtually failure-free performance in nearly all types of conditions.

The internally shielded, DC operated EE includes an electric field generator, a field receiver, sinusoidal-shaped dielectric rotor, and processing electronics.

The EE output is a digital serial synchronous with absolute position single turn.

This combination of high precision, low profile and, low weight has made Netzer precision encoders highly reliable and particularly well suited to a wide variety of industrial automation applications.

Electrical

Supply voltage	5V ± 5%
Current consumption	<90 mA
Interconnection	Cable (standard 250mm)

Environmental

EMC	IEC 6100-6-2, IEC 6100-6-4
Operating temperature	-40°C to +85°C
Storage temperature	-40°C to +125°C
Relative humidity	98% Non condensing
Shock endurance	100 g for 11 ms
Vibration endurance	20 g 10 – 2000 Hz
Protection	IP 40

Calibration / Compensation

Offsets	Automatic / Manual
Signals level	Automatic / Manual
Signals integrity	Error / Warning report
Thermal	Error / Warning report
Zero position	Manual

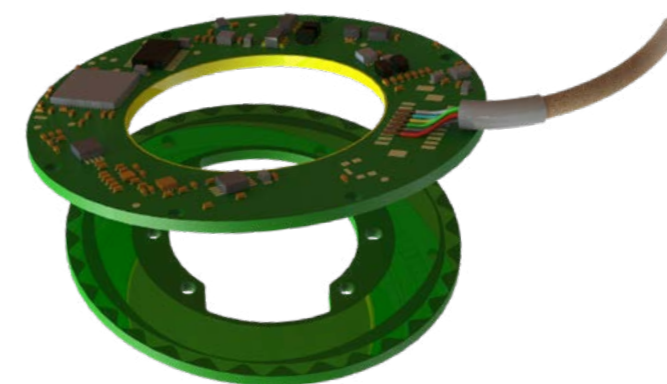



Digital SSI Interface

Synchronous Serial Interface (SSI) is a point to point serial interface standard between a master (e.g. controller) and a slave (e.g. sensor) for digital data transmission.

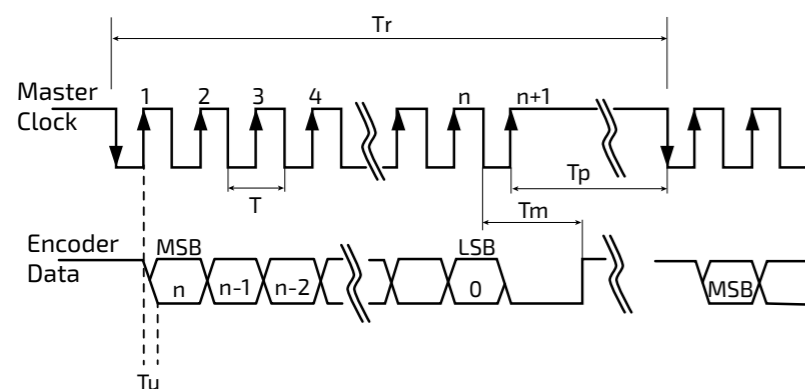

SSI / BiSS output signal parameters

Output code	Binary
Serial output	Differential RS-422
Clock	Differential RS-422
Clock frequency	0.1 ÷ 5.0 MHz
Position update rate	35 kHz (Optional - up to 375 kHz)

SSI / BiSS interface wires color code

Clock + / NCP RX +	Grey	Clock
Clock - / NCP RX -	Blue	
Data - / NCP TX -	Yellow	Data
Data + / NCP TX +	Green	
GND	Black	Ground
+5V	Red	Power supply

	Description	Recommendations
n	Total number of data bits	12 - 22
T	Clock period	
f = 1/T	Clock frequency	0.1 - 5.0 MHz
Tu	Bit update time	90 nsec
Tp	Pause time	26 - ∞ μsec
Tm	Monoflop time	>25 μsec
Tr	Time between 2 adjacent requests	Tr > n*T + 26 μsec
fr = 1/Tr	Data request frequency	

Software tools: (SSI / BiSS - C)

Advanced calibration and monitoring options are available by using the factory supplied **Electric Encoder Explorer** software. This facilitates proper mechanical mounting, offsets calibration and advanced signal monitoring.

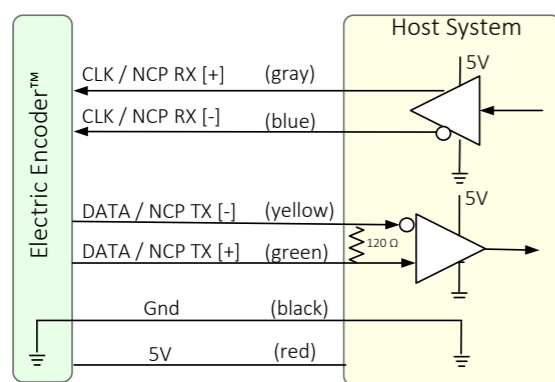
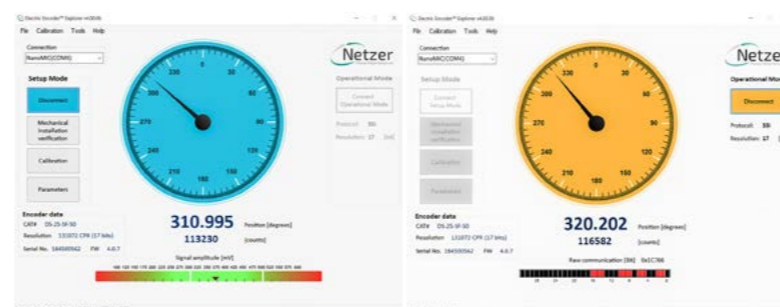

Digital BiSS-C Interface

BiSS - C Interface is unidirectional serial synchronous protocol for digital data transmission where the Encoder acts as "slave" transmits data according to "Master" clock. The BiSS protocol is designed in B mode and C mode (continuous mode). The BiSS-C interface as the SSI is based on RS-422 standards.

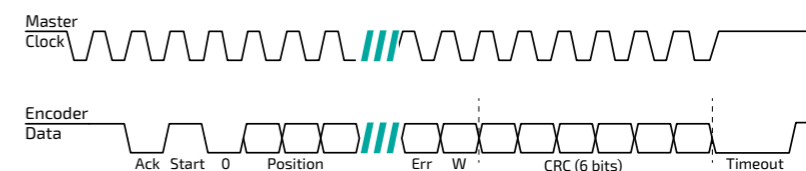

Bit #		Description	Default	Length
27	Ack	Period during which the encoder calculates the absolute position, one clock cycle	0	1/clock
26	Start	Encoder signal for "start" data transmit	1	1 bit
25	"0"	"start" bit follower	0	1 bit
8...24	AP	Absolute Position encoder data		
7	Error	Error (amplitude levels)	1	1 bit
6	Warn.	Warning (non active)	1	1 bit
0...5	CRC	The CRC polynomial for position, error and warning data is: $x^6 + x^1 + x^0$. It is transmitted MSB first and inverted. The start bit and "0" bit are omitted from the CRC calculation.		6 bits
	Timeout	Elapse between the sequential "start" request cycle's.		25 μs

Ordering Code

VLP - 60 - S G - S 0 - n n n

VLP Product line

Outer Diameter

Output

S	SSi
I	BiSS

Resolution

Code	Bit	CPR
G	18	262,144
H	19	524,288
I	20	1,048,578

EA Extended Accuracy

nnn Custom

Interconnection

0	250mm Flying leads (default)
1	500mm Flying leads
2	750mm Flying leads
3	1000mm Flying leads
C	Connector (optional)

S Shielded cable 250 mm

Cable Information

Cable: 30 AWG twisted pair (3):
2 (30 AWG 25/44 tinned copper, Insulation: PFE \varnothing 0.15 to \varnothing 0.6 \pm 0.05 OD)
Temperature rating: -60 to +150 Deg C
Braided shield: Thinned copper braided 95% min. coverage
Jacket: 0.44 silicon rubber (NFA 11-A1) \varnothing 3.45 \pm 0.2 OD

Pair #	Color
A1-A2	Red / Black
A3-A4	Gray / Blue
A5-A6	Green / Yellow

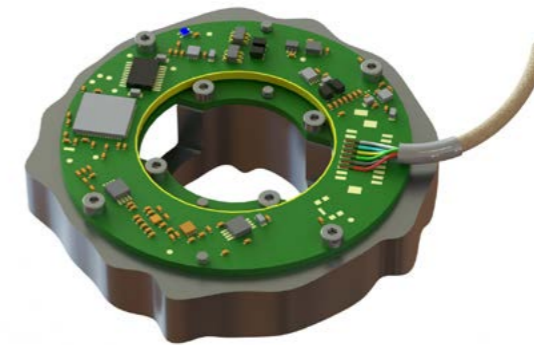
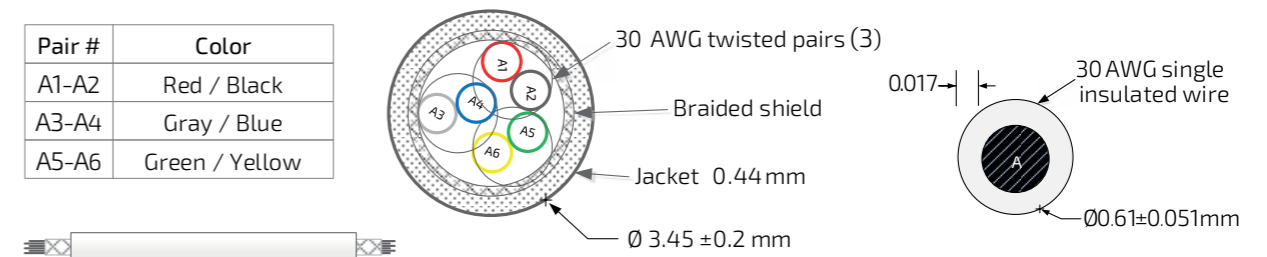

Related Documents

VLP-60 User Manual: Mechanical, Electrical and calibration setup.

Optional Accessories

Demonstration Kit

DKIT-VLP-60-SG-S0 - SSi interface

DKIT-VLP-60-IG-S0 - BiSS interface

The demo-kit includes: mounted encoder on rotary jig, and RS-422 to USB converter.

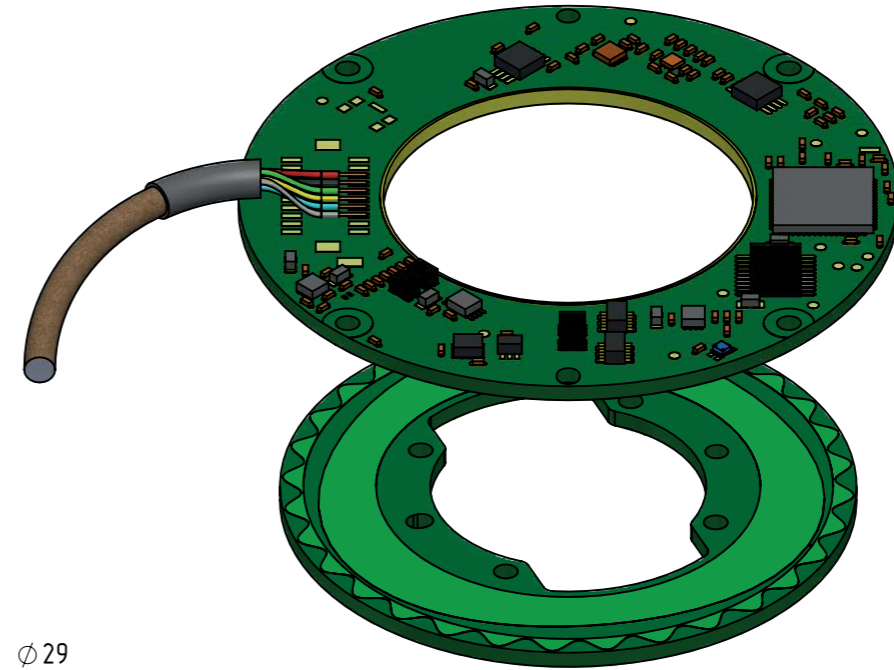
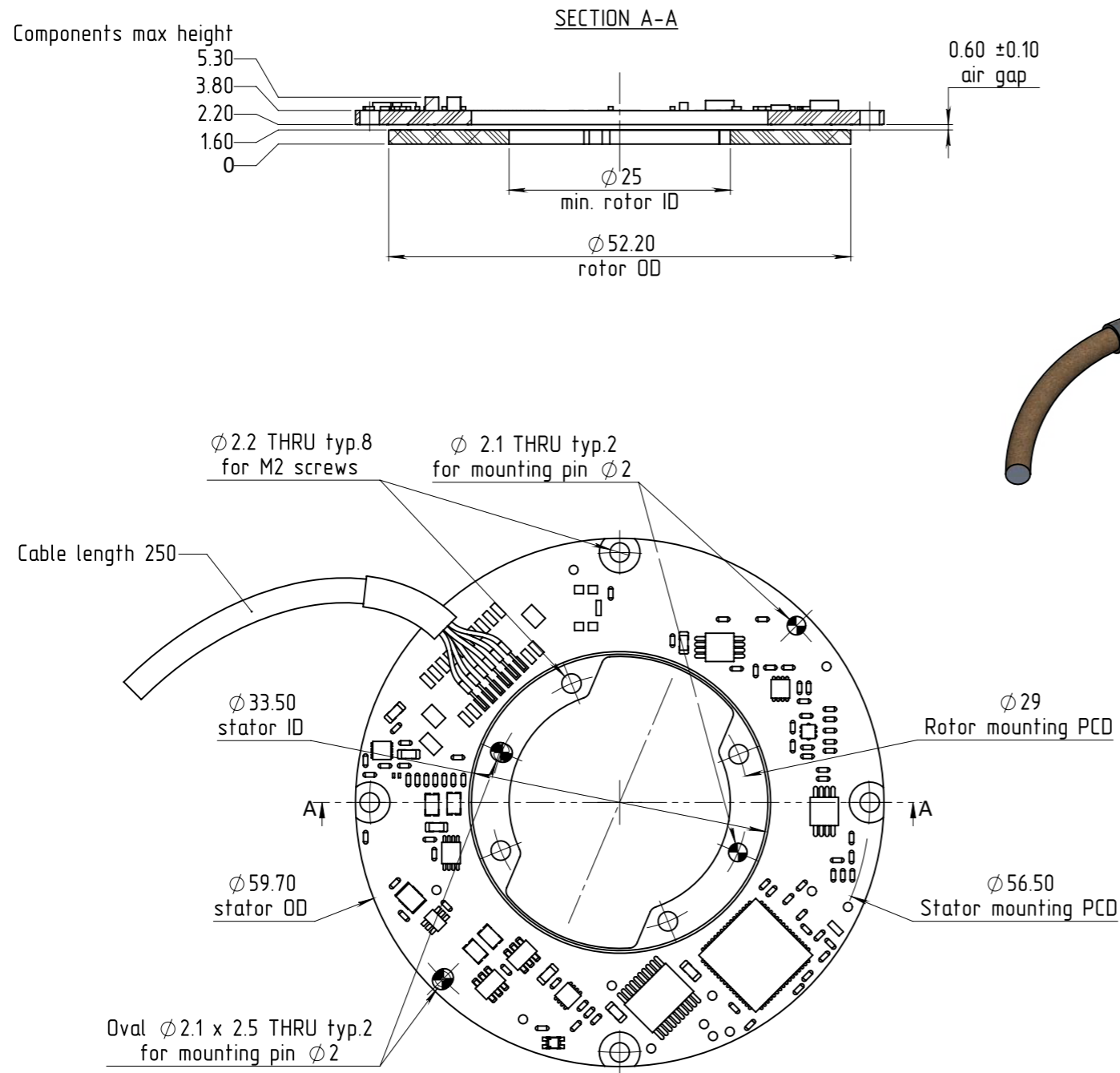

Unless Otherwise Specified

Dimensions are in: mm	Surface finish: N6
Linear tolerances	
0.5-4.9: ±0.05 mm	5-30: ±0.1 mm
31-120: ±0.15 mm	121-400: ±0.2 mm