

DRACO

Dual-Axis Servo Drive

Rugged
300 VDC or 600 VDC
Up to 120 Amps



ESI Motion's Draco Servo Drive provides power house performance in a small, lightweight package. Draco incorporates our rugged, high-density DSP controller and power driver modules, offers several feedback options, and is packaged in a military-grade submersible case.

This versatile servo drive is ideal for high-performance applications operating at high temperatures, in high vibration, or other extreme environmental conditions. ESI Motion's servo drive systems are designed for precision military, aviation, automotive, robotics, and specialized industrial applications where size and weight are critical. ESI Motion products are designed and built at our USA facility.

Features:

- MIL-STD-461 EMI Filter
- Nominal Voltage Options: 300VDC or 600VDC
- Maximum Continuous Output Current to 120A
- Maximum DC Power to 33.35 kW
- Multiple Feedbacks Supported:
 - BiSS-C
 - Quadrature Encoder
 - Resolver
 - Hall
 - Sensorless
- Maximum Motor Speed 75,000 RPM
- Torque, Velocity, or Position control
- Brake drivers
- Optional Reverse Current Flow Protection
- Regeneration Controller
- Active Inrush Limiter
- Includes configurable, user-friendly GUI with enhanced data collection capability and integrated oscilloscope feature

Specifications:

- Operating Case Temperature: -40 to 71°C
- Weight: 2.36 – 3.30 kg (5.20 – 7.27 lbs.)
- Size: 238 x 159 x 66 mm – 250 x 174 x 77 mm
- Efficiency: >97% (full load)

Compliance:

- Electromagnetic interference per MIL-STD-461:
 - CE102
 - CS101
 - CS114
 - CS115
 - CS116
 - RE101
 - RE102
 - RS103
- Shock/Vibration per MIL-STD-810G:
 - Random Vibration 514.7 Category: 16.3 Grms, 15 – 2,000 Hz (0.20 g²/Hz)
 - Shock 516.7 Procedure 1: 40G Terminal Peak Sawtooth, 11ms
- 28V Electrical power characteristics: MIL-STD-704F
- Optional Software design assurance: DO-178C

Customization Available

ESI Motion has the expertise to customize a solution for your project's needs. Contact us today at sales@esimotion.com to see how we can tailor a solution for you.

Typical Draco Application:

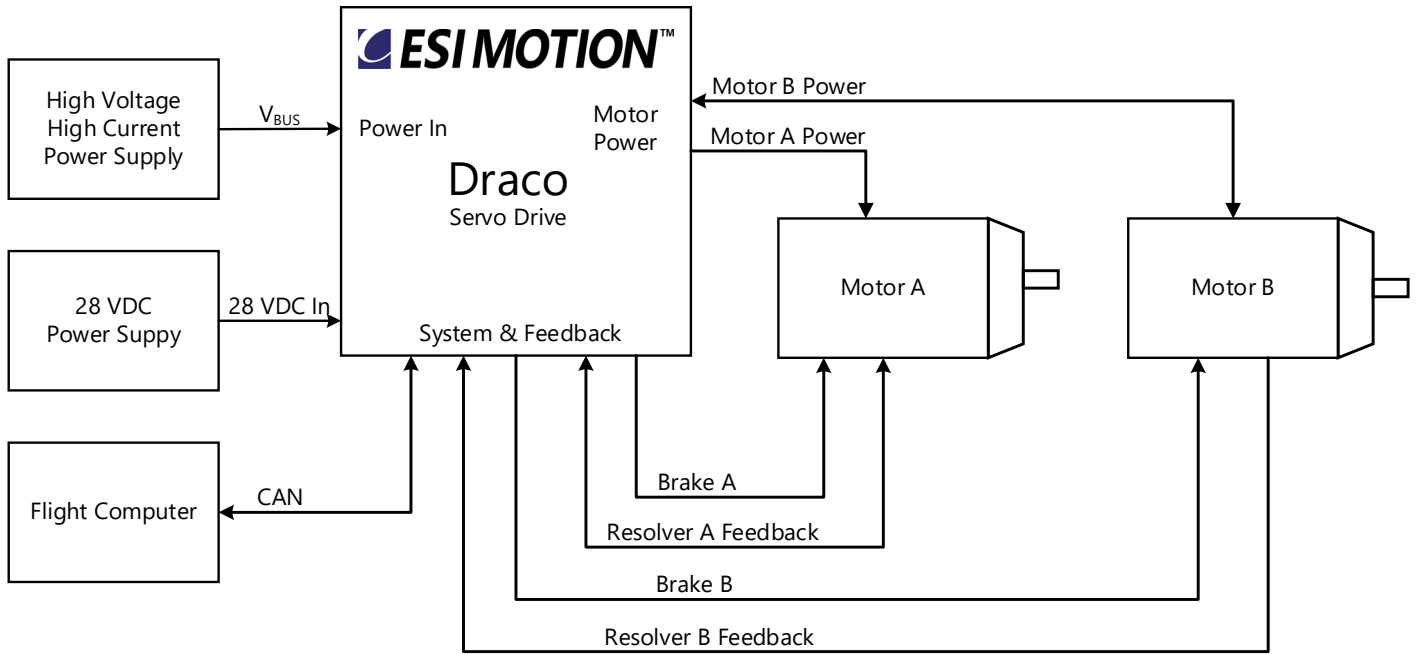

Draco Block Diagram:

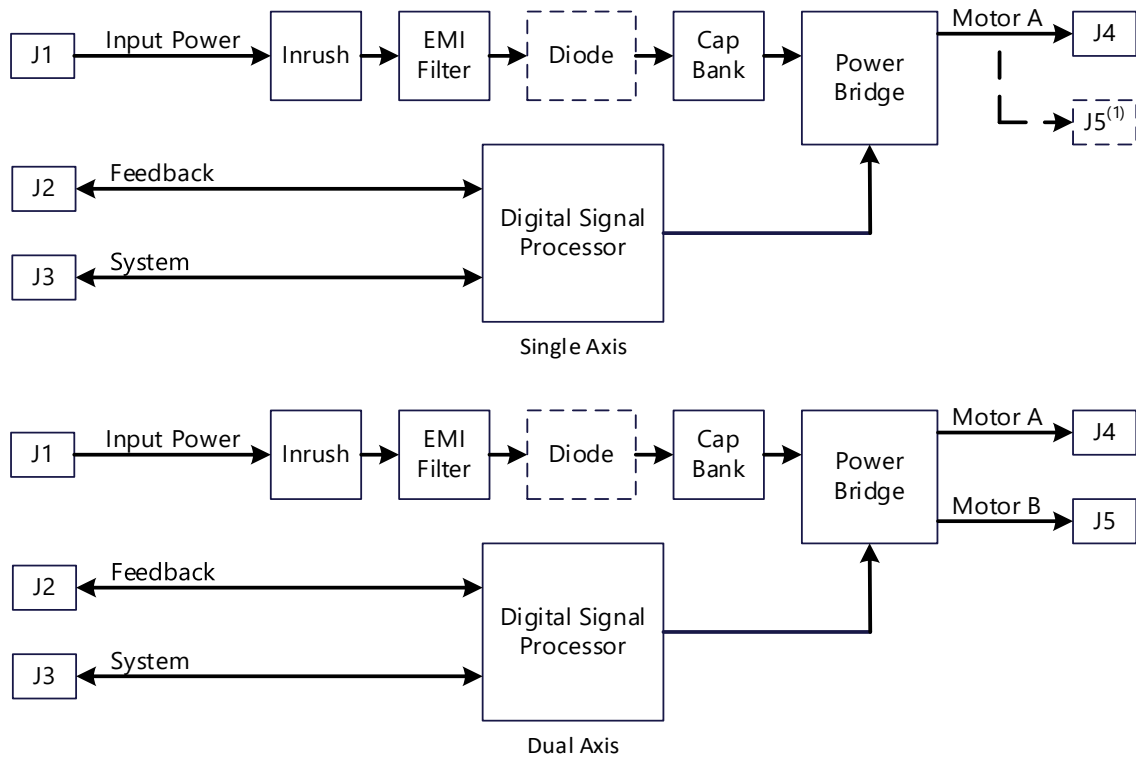

Notes:

1. See the Motor Power Connector section to determine the presence of J5.

Electrical Specifications

Absolute maximum values

The values in the table below should never be exceeded as permanent damage to the controller may result.

PARAMETER		ABSOLUTE MAXIMUM	UNIT
V_BUS (Motor Power), 600V model		900	VDC
V_BUS (Motor Power), 300V model		450	VDC
28VDC_IN (Logic Power)		50	V
±10 Volt Analog Inputs		±22	V
±5 Volt Analog Inputs (Resolver Inputs)		±22	V
Single Ended Analog Input		±22	V
Open Collector Inputs (Hall Inputs)		±22	V
CAN SIGNALS	Differential (CAN+ – CAN-)	±27	V
	Common-Mode	±27	V
Isolated CAN SIGNALS	Differential (CAN+ – CAN-)	±27	V
	Common-Mode	±250	V
RS-422 Inputs		±14	V
Differential Digital Inputs (Encoder and BiSS-C Inputs)	Differential (Assumes 50% Duty Cycle)	7.6	V
	Common-Mode	±7.0	V
Digital Input		+4.6	V
Temperature Sensor Input		-3 to +6	V
Operating case temperature		-40 to +71	°C
Storage Temperature		-55 to +100	°C

Recommended operating conditions

Motor Power DC Input Characteristics – 600 VDC Model				
Parameter	Min	Nom	Max	Units
V_BUS (Motor Power)	50	600	725	VDC
V_BUS (Motor Power) Input Current			46	Amps
Input Power		27.6	33.35	kW
Internal Bus Capacitance		54		uF
Chassis Capacitance (Common Mode)		12		uF

Notes:

1. Power is limited by the EMI filter current capability. Higher power customized solutions are available.

Motor Power DC Input Characteristics – 300 VDC Model

Parameter	Min	Nom	Max	Units
V_BUS (Motor Power), 300V Model	50	300	400	VDC
V_BUS (Motor Power) Input Current			46	Amps
Input Power ⁽¹⁾		13.8	18.4	kW
Internal Bus Capacitance (Differential Mode)		114		uF
Chassis Capacitance (Common Mode)		12		uF

Notes:

1. Power is limited by the EMI filter current capability. Higher power customized solutions are available.

28 Volt Logic DC Input Characteristics

Parameter	Min	Nom	Max	Units
28VDC_IN Operating Voltage	22	28	36	VDC
28VDC_IN Operating Current w/o Brakes			0.75	A
28VDC_IN Operating Current			4.25	A

Notes:

Motor Power Output Characteristics

Parameter (Per Axis)	Continuous	Peak ⁽²⁾	Units
output current, 20A Model	20	40	Amps Peak-of-Sin
output current, 40A Model ⁽¹⁾	40	80	Amps Peak-of-Sin
output current, 60A Model ⁽¹⁾	60	80	Amps Peak-of-Sin
output current, 80A Model ⁽¹⁾	80	80	Amps Peak-of-Sin
output current, 120A Model ⁽¹⁾	120	120	Amps Peak-of-Sin
Motor Speed		75,000	RPM

Notes:

1. Output power may be limited by the maximum input current
2. Two Second Peak

I/O Characteristics

Parameter	Min	Nom	Max	Unit
Encoder Power				
5VDC_OUT				
Output Voltage	4.75	5.0	5.25	VDC
Output Current		500		mA
± 10 Volt Analog Inputs				
ANALOG_IN_1, ANALOG_IN_2				
Input Range	-10		+10	V
Common Mode Input Range	-8.0	0	+10.0	V
Impedance		20.0		KΩ

I/O Characteristics				
Parameter	Min	Nom	Max	Unit
Input Bandwidth		100		kHz
Resolver SIN, COS (ANALOG_IN_3 – ANALOG_IN_6) SIN+MA, SIN-MA, COS+MA, COS-MA, SIN+MB, SIN-MB, COS+MB, COS-MB Alternate Function Name ANALOG_IN_3+, ANALOG_IN_3-, ANALOG_IN_4+, ANALOG_IN_4- ANALOG_IN_5+, ANALOG_IN_5-, ANALOG_IN_6+, ANALOG_IN_6-				
Differential Range	2		4.2	V _{RMS}
Differential Impedance		20		KΩ
Input Bandwidth		70		kHz
Open Collector Inputs (Hall Inputs) HALL_A_MA, HALL_B_MA, HALL_C_MA, HALL_A_MB, HALL_B_MB, HALL_C_MB Alternate Function Name DIGITAL_IN_1, DIGITAL_IN_2, DIGITAL_IN_3, DIGITAL_IN_4, DIGITAL_IN_5, DIGITAL_IN_6,				
Input Voltage	0		10	V
Internal Pull Up Voltage	4.5	5.0	5.5	V
Internal Pull Up Impedance		1.0		kOhm
Logic High Voltage		1.95		V
Logic Low Voltage		1.07		V
Input Hysteresis		0.88		V
CAN Signals CAN+, CAN-, ISO_CAN+, ISO_CAN-				
Voltage Levels	Compliant to ISO 11898-2			
Standard Bit Rates	100, 250, 500, and 1,000			Kbps
RS422 Signals RS422_TX, RS422_RX				
Voltage Levels	Compliant to EIA-422-B			
Standard Bit Rates	115.2, 230.4, 460.8, 1000			Kbps
Encoder, Hall, BiSS-C, and Auxiliary Equipment Power Signals 5VDC_OUT, SIGNAL_GND				
Output Voltage	4.75	5.0	5.25	Volts
Output Current (Total for all 5VDC_OUT connections)			500	mA
Brake BRAKE+MA, BRAKE-MA, BRAKE+MB, BRAKE-MB				
Output Voltage		98%		Percent of 28VDC_IN
Output Current Limit	1.3	1.4	1.5	Amps
Encoder and BiSS-C Signals A+MA, A-MA, B+MA, B-MA, I+MA, I-MA, A+MB, A-MB, B+MB, B-MB, I+MB, I-MB				
Voltage Levels	Compliant to EIA-422-B			
Differential Input Impedance		120		Ohms

I/O Characteristics				
Parameter	Min	Nom	Max	Unit
Input Frequency			25	MHz
Motor Temperature MOTOR_TEMP+, MOTOR_TEMP-				
Thermistor Resistance at 25°C	1	5	10	KΩ
Recommended Thermistor	TDK/Epcos PN B57861S0502F040			
Excitation Voltage		3.0		V
Excitation Impedance		2.0		kOhm
Input Bandwidth		1.6		kHz
Resolver Excitation EXE+MA, EXE-MA, EXE+MB, EXE-MB				
Output Voltage	3.8	4	4.2	V _{RMS}
Resolver Excitation Output Frequency ⁽¹⁾		5.0		kHz
Analog Output ANALOG_OUT_1, ANALOG_OUT_2				
Output Range	-3		+3	V
Analog Output Impedance		50		Ω
Update Rate		2X		PWM Frequency
Interlock INTERLOCK+MA, INTERLOCK-MA INTERLOCK+MB, INTERLOCK-MB,				
Interlock Short Resistance	0		1 K	Ohm
Interlock Open Resistance	1 Meg			Ohm
Regen REGEN+, REGEN-				
Continuous Current			23	Amps
Peak (2 Second) Current			40	Amps
Thermal Information				
Core to Ambient Thermal Resistance		TBD		°C/W
Core to Sink Thermal Resistance		TBD		°C/W
Maximum Case Temperature			71	°C

Notes:

1. Default resolver frequency is 5 kHz (contact ESI for custom frequencies)

Mechanical Characteristics & Connectors

Mechanical Characteristics			
Parameter		Value	Units
Weight,	Conduction-Cooled, Single Motor Power Connector	2.36 (5.20)	Kg (lbs.)
	Conduction-Cooled, Dual Motor Power Connectors	2.62 (5.78)	
	Liquid-Cooled, Single Motor Power Connector	3.04 (6.69)	
	Liquid -Cooled, Dual Motor Power Connectors	3.30 (7.27)	
Size	Conduction-Cooled, Single Motor Power Connector	238 x 159 x 66	mm
	Conduction-Cooled, Dual Motor Power Connectors	238 x 174 x 66	
	Liquid-Cooled, Single Motor Power Connector	250 x 159 x 77	
	Liquid -Cooled, Dual Motor Power Connectors	250 x 174 x 77	

Notes:

Connectors							
No.	Function	Insert Arrangement	Clacking	Number of contacts	Contact size	Connector Part Number	Mating Connector Part Number
J1	Input Power	21-11	Normal	11	12	D38999/24FG11PN	D38999/26FG11SN
J2	Feedback	17-35	Normal	55	22D	D38999/24FE35PN	D38999/26FE35SN
J3	System	15-35	Normal	37	22D	D38999/24FD35PN	D38999/26FD35SN
J4	Motor Power Output	21-11	Normal	11	12	D38999/20FG11SN or D38999/24FG11SN	D38999/26FG11PN
J5 ¹	Motor Power Output	21-11	"A"	11	12	D38999/20FG11SA	D38999/26FG11PA

Notes:

1. Not included on all controllers. See Motor Power section to determine if a configuration includes J5.

Draco Interconnect Diagram

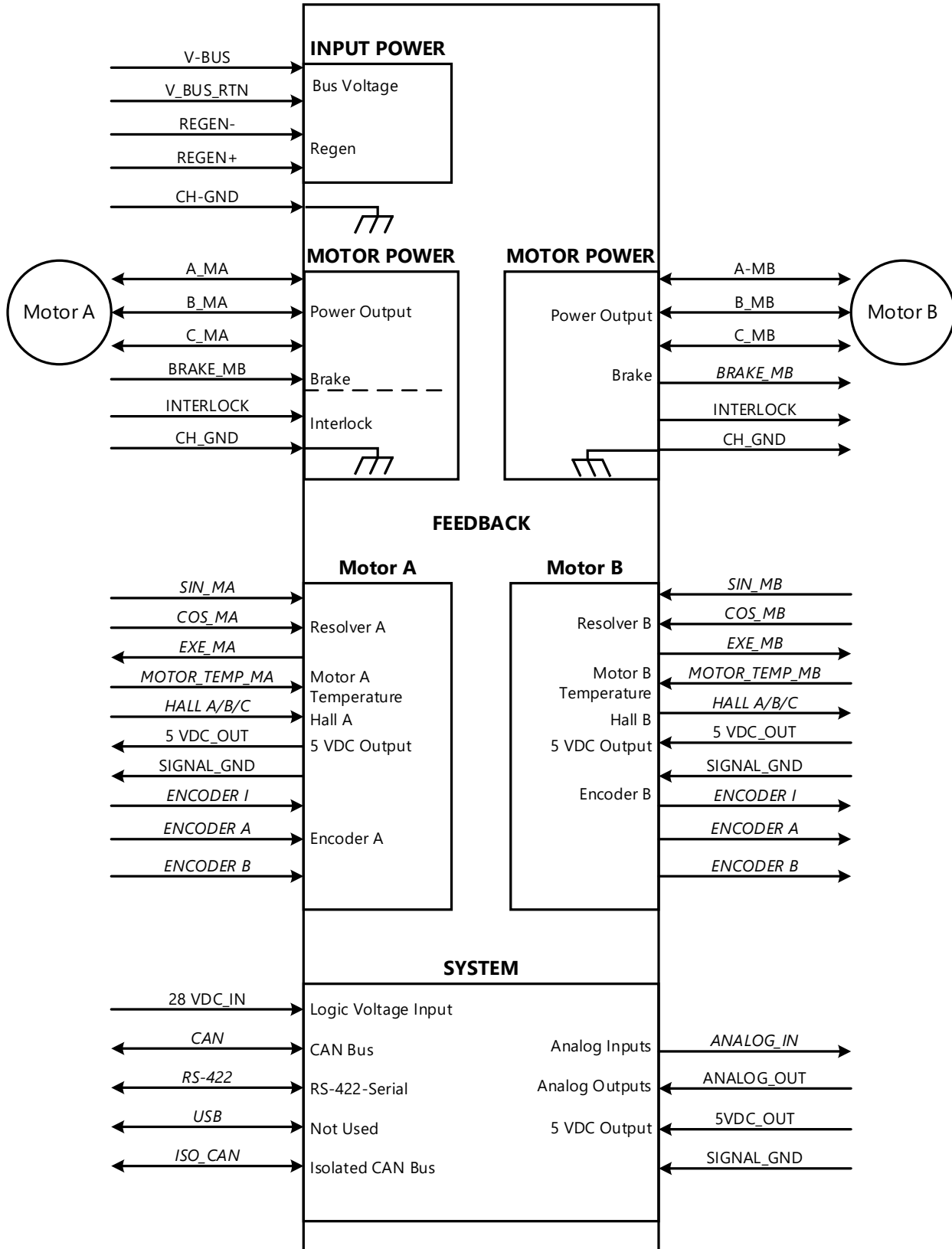

Interfaces Description

Overview

The Draco servo drive is a rugged servo controller with very high-power capability in a small size and low weight package. This section describes the Draco electrical interfaces by functional group.

Power Input (J1)

Motor power (V_BUS) is supplied to the Draco through the Power Input connector. This connector also includes the connection for an external regen resistor.

Motor Feedback (J2)

The motor feedback interface is connected to the Motor Feedback connector.

The Draco servo drive supports the following motor feedback devices:

- Resolver
- Quadrature Encoder
- Hall
- BiSS-C
- Sensorless.

Feedback options are software configurable via HiDS.

The connector provides connector for a motor thermistor. It is compatible with a negative temperature coefficient (NTC) thermistor. The temperature vs. resistance can be configured through software.

Two 24V brake drivers are provided. The brake drives normally power brakes in application to prevent Z-axis movement while the motor is disabled. The brakes are electrically asserted when the motor is enabled.

An auxiliary 5-volt power supply (5VDC_OUT) is provide to power encoders, hall sensors, or other 5 volt devices. Several 5VDC_OUT signals are provided for ease of connection to multiple devices. Internally, all of the 5VDC_OUT are connected together. The current rating for the 5VDC_OUT is the combined current of all of the 5VDC_OUT signals. The return signal for 5VDC_OUT is SIGNAL_GND.

System Interface (J3)

The connector provides user interface signals. This interface includes 28 VDC power input (28VDC_IN and 28VDC_RTN) to power the Draco's logic circuits. Do not connect the 28VDC_RTN to the SIGNAL_GND. The 28VDC_RTN is pre-EMI filter while the SIGNAL_GND is post-EMI filter.

ESI recommends communication via a CAN network. CAN is ideal for real-time embedded networking. It is proven to be robust as well as flexible. The supported CAN protocol can be downloaded from the ESI web site. ESI plans to support CANOpen in a future software update.

RS-422 is a good alternate to CAN. It is robust like CAN but not as flexible. The supported RS-422 protocol can be downloaded from the ESI web site.

USB is not supported. Do not connect the USB to a computer while the Draco is enabled as the USB is highly susceptible to noise and has been known to damage USB ports on the computer.

A separate isolated CAN interface is provided with the following signals:

- ISO_CAN+
- ISO_CAN-
- ISO_GND



The isolated CAN allows communication on system without a common ground.

While ESI recommends a digital system interface such as CAN or RS-422, analog inputs and outputs are provided for legacy systems where digital communication is not possible.

Motor Power (J4, J5)

The Motor Power connector provides three-phase power to the motor.

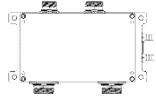
Single Axis units rated for under 60 amps include J4 only while Single Axis units rated for more than 80 amps include both J4 and J5. All Dual Axis units include J4 and J5. Single Axis units rated for more than 80 amps must parallel the connections on J4 and J5 in order to meet the published current rating. See the table below to determine if a unit includes two connectors based on the rated current and the number of axes.

Rated Current	Single-Axis	Dual-Axis
20		
40		
60		
80		Contact ESI
120		Contact ESI

Interlock connections are provided for each motor connector. The interlock is a safety feature which prevents high voltage from being applied to the motor when the interlock is broken. Ideally the interlock signals are shorted together inside the motor. If the motor cable is disconnected, the Interlock is broken and the unit will not apply high voltage to the motor power connector. The interlock loop must be shorted on every connector before the user can enable any motor. If the loop is broken, both motors are disabled. The interlock can be enabled via software.

Digital and Analog IO signals can be configured by ESI Motion's "HiDS" motor controller software tool for use in the end application.

Digital units can be configured for various functions such as drive enable. Analog inputs can be configured as inputs to the system as well. For example, the analog inputs can be used to give the Draco servo drive a torque or velocity command. They can also be used to inject a test signal for use with a Dynamic Signal Analyzer or other test equipment.

Analog outputs can be setup in HiDS to represent an analog value for any variable in software in real-time. The unit provides two analog outputs. The user must account for the output impedance of the analog output when using these signals.

This analog input is provided to support legacy analog systems. ESI recommends the use of a digital interface (CAN or RS-422) when possible.

ESI Motion's HiDS Application

The Host Interface for Drive/Servo Controller (HiDS) is ESI Motion's servo motor controller software tool.

This innovative application allows users to configure a servo motor control system quickly, and with a great deal of flexibility. It's based upon a configurable, user-friendly GUI, with an integrated oscilloscope feature. Extensive data collection and control allows system tuning and troubleshooting.

On Draco, the HiDS functions can be accessed via CAN. HiDS and the Controller User's Manual can be downloaded from ESI Motion's website at: <https://www.esimotion.com/support/downloads/>

ESI's motion control products employ industry-standard current-loop, velocity-loop, and in some applications, a position-loop. Each of these control loops utilizes Proportional, Integral, and Derivative (PID) error correction to achieve the desired performance. The Controller User's Manual includes a procedure for tuning each control loop to match the intended application. After the tuning is completed, additional initial configuration using feedback is described in detail.

The Controller User's Manual walks you through the steps to set up limits, enter motor parameters, and tune the motor using the desired loop configuration. An excerpt from the summary tab shown below is an example view of key device configuration parameters:

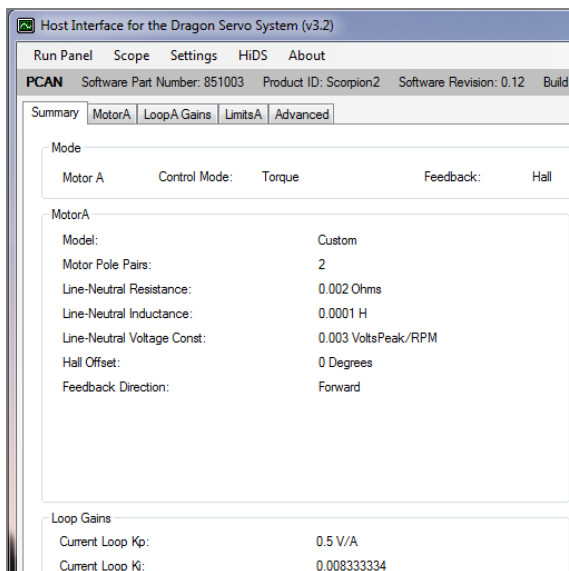

HiDS allows extreme flexibility via simply changing parameters, without the need to reload custom software.

The HiDS Run Panel facilitates control commands and monitoring of parameters such as motor speed and current:



A typical velocity-loop step response, displayed on the built-in oscilloscope function, is shown below:

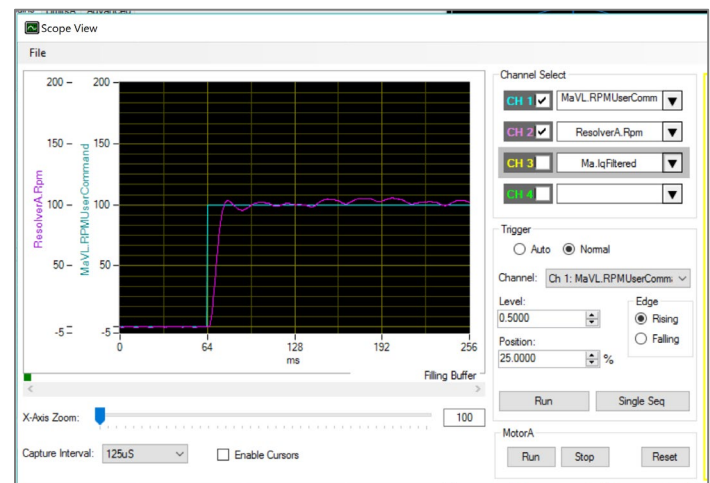

The design of the ESI Motion Draco servo controller and HiDS tool allow for tremendous flexibility and capabilities in motor control and monitoring, to ensure success of the most challenging motion control applications.

Envelope and Dimensions
Mechanical Dimensions - Chassis Cooled
All Dimensions are in Inch. Tolerance: +- 0.01"

20A, 40A, and 60A Single-Axis Units

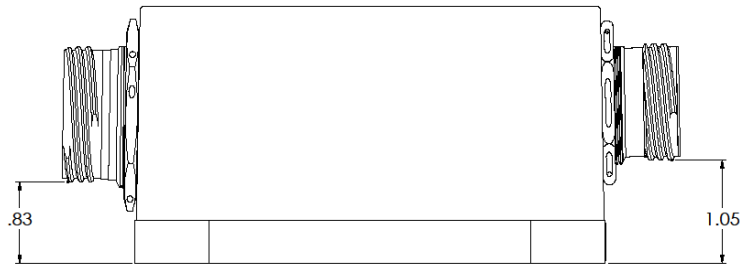
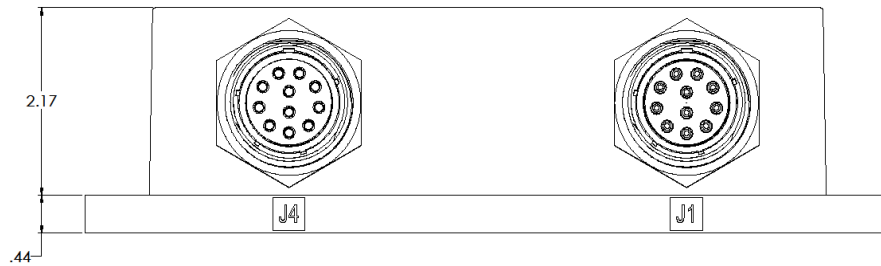
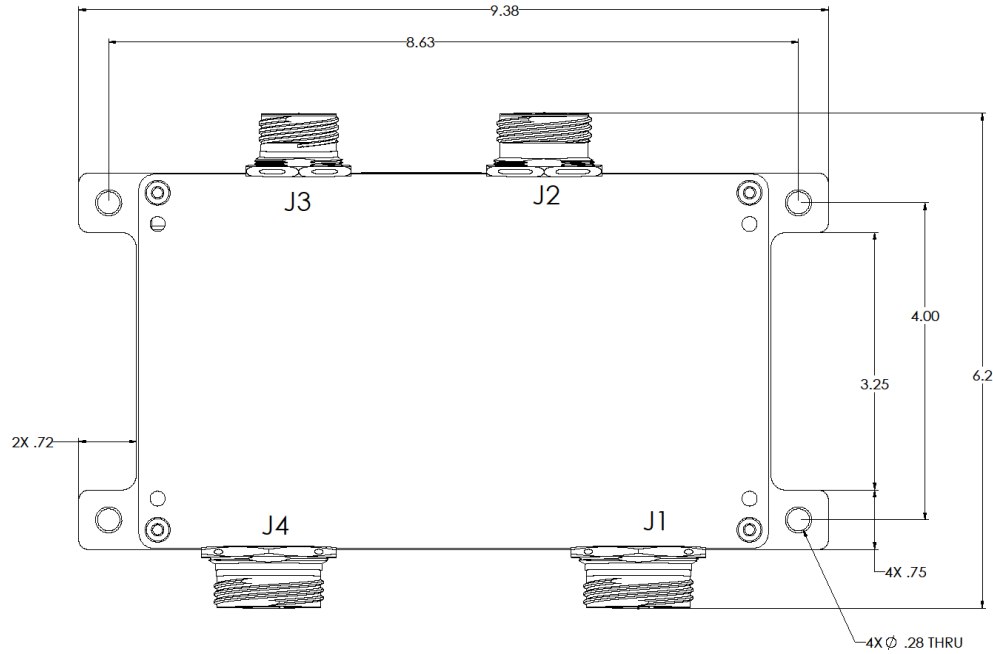

80A, 120A Single-Axis, All Dual-Axis Units

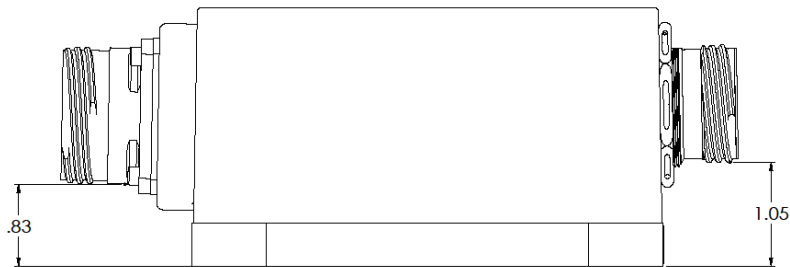
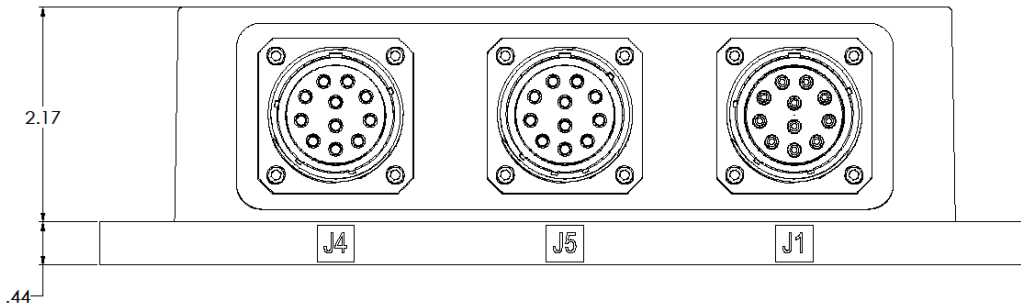
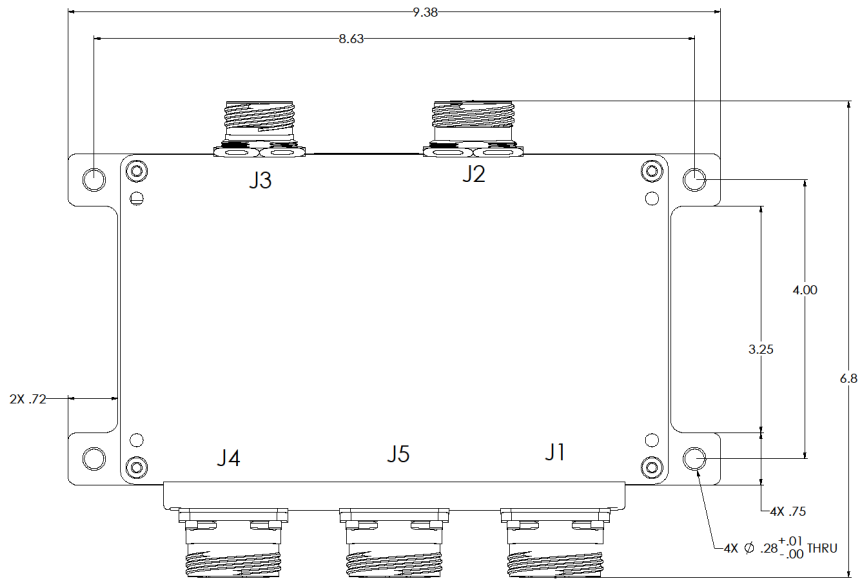

Mechanical Dimensions – Liquid Cooled

20A, 40A, and 60A Single-Axis Units

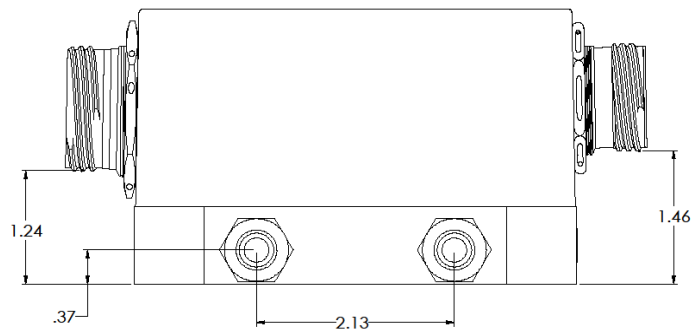
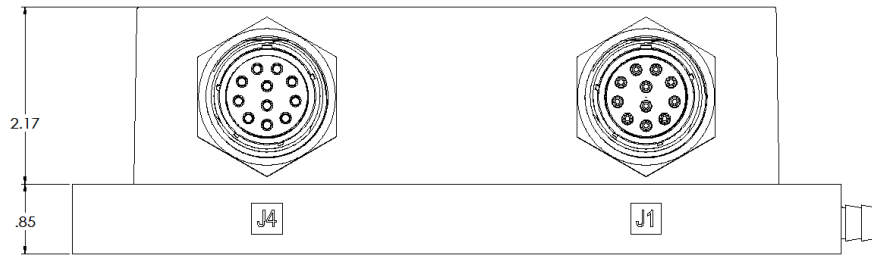
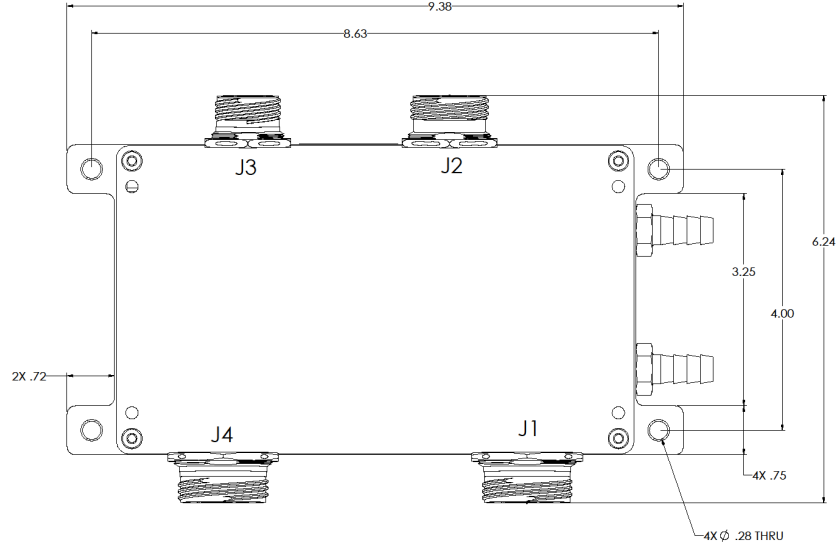

80A, 120A Single-Axis, All Dual-Axis Units

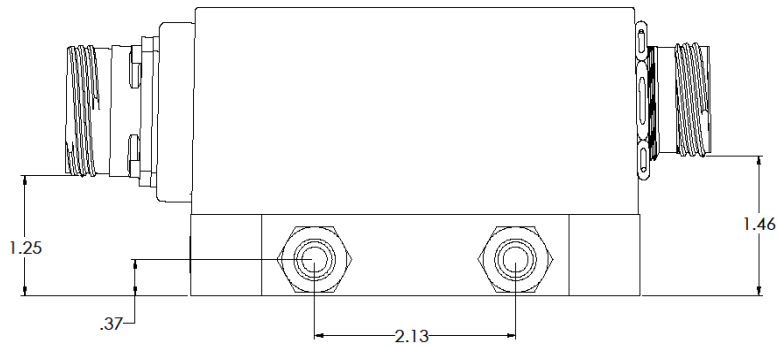
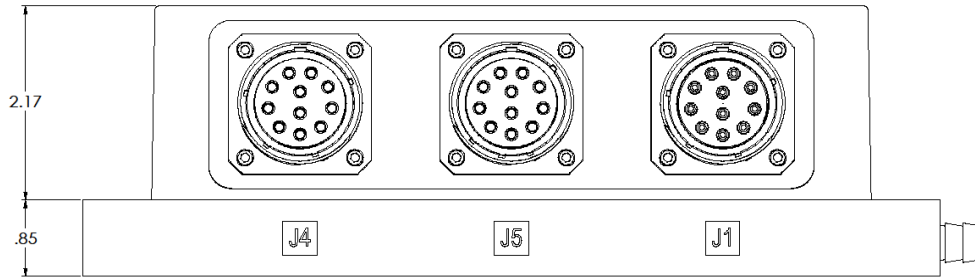
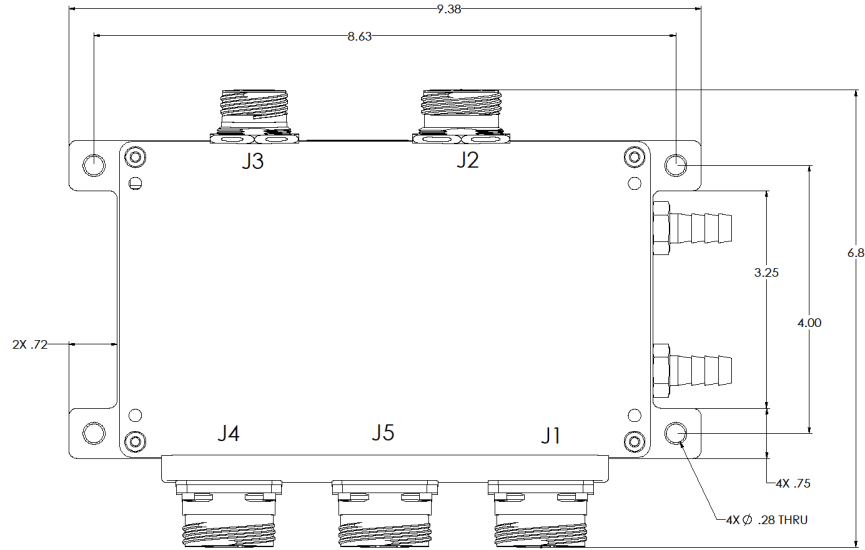

Connector Pinouts

Interfaces for each of the six connectors are shown in this section. See each respective diagram for the pinout numbering.

J1 Input Power Pinout Assignments

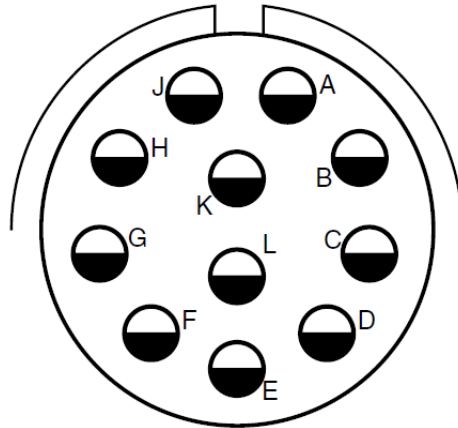

View looking into case connector

J1 Pin	Name	I/O	Description	Type
A	V_BUS_RTN	IN	Motor Power Return	Power
B	V_BUS_RTN	IN	Motor Power Return	Power
C	Reserved	---	Do not connect	
D	REGEN-	OUT	External Regen Resistor Connection	Power
E	REGEN+	OUT	External Regen Resistor Connection	Power
F	Reserved	---	Do not connect	
G	Reserved	---	Do not connect	
H	V_BUS	IN	Motor Power	Power
J	V_BUS	IN	Motor Power	Power
K	Reserved	---	Do not connect	
L	CH_GND	---	Chassis Ground	Chassis Ground

J2 Feedback Pinout Assignments

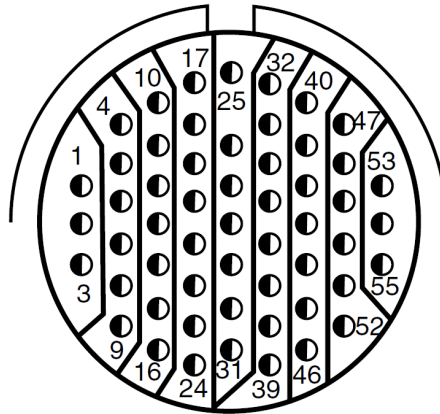

View looking into case connector

J2 Pin	Name	I/O	Description	Type
1	CH_GND	---	Chassis Ground ⁽¹⁾	Chassis Ground
2	EXE+MA	OUT	Resolver excitation output positive motor A	Resolver
3	EXE-MA	OUT	Resolver excitation output negative motor A	Resolver
4	SIN+MA (ANALOG_IN_3+)	IN	Resolver SIN positive motor A, can be used as ANALOG_IN_3+	Resolver Input ±5 Volt Analog Input
5	SIN-MA (ANALOG_IN_3-)	IN	Resolver SIN negative motor A, can be used as ANALOG_IN_3-	Resolver Input ±5 Volt Analog Input
6	COS+MA (ANALOG_IN_4+)	IN	Resolver COS positive motor A, can be used as ANALOG_IN_4+	Resolver Input ±5 Volt Analog Input
7	COS-MA (ANALOG_IN_4-)	IN	Resolver COS negative motor A, can be used as ANALOG_IN_4-	Resolver Input ±5 Volt Analog Input
8	EXE+MB	OUT	Resolver excitation positive motor B	Resolver Output
9	EXE-MB	OUT	Resolver excitation negative motor B	Resolver Output
10	SIN+MB (ANALOG_IN_5+)	IN	Resolver SIN positive motor B, can be used as ANALOG_IN_5+	Resolver Input ±5 Volt Analog Input
11	SIN-MB (ANALOG_IN_5-)	IN	Resolver SIN negative motor B, can be used as ANALOG_IN_5-	Resolver Input ±5 Volt Analog Input
12	COS+MB (ANALOG_IN_6+)	IN	Resolver COS positive motor B, can be used as ANALOG_IN_6+	Resolver Input ±5 Volt Analog Input
13	COS-MB (ANALOG_IN_6-)	IN	Resolver COS negative motor B, can be used as ANALOG_IN_6-	Resolver Input ±5 Volt Analog Input
14	MOTOR_TEMP+MA	IN	Temperature positive motor A	Temperature Sensor Input
15	MOTOR_TEMP-MA	IN	Temperature negative motor A	Temperature Sensor Input
16	MOTOR_TEMP+MB	IN	Temperature positive motor B	Temperature Sensor Input
17	MOTOR_TEMP-MB	IN	Temperature negative motor B	Temperature Sensor Input
18	5VDC_OUT	OUT	5 Volt Encoder/Hall/Aux Power	Low Voltage Power
19	SIGNAL_GND	---	5VDC_OUT Return and Ground Reference ⁽²⁾	Ground
20	A+MB (BISS_CLK+MB)	IN OUT	Quadrature encoder A positive BiSS-C clock positive motor B	Differential Digital In Differential Digital Out
21	A-MB (BISS_CLK-MB)	I/O	Quadrature encoder A negative BiSS-C clock negative motor B	Differential Digital In Differential Digital Out
22	B+MB	IN	Quadrature encoder B positive motor B	Differential Digital Input
23	B-MB	IN	Quadrature encoder B negative motor B	Differential Digital Input

⁽¹⁾ This document does not contain Technical Data or Technology as defined the ITAR Part 120.10 or EAR Part

J2 Pin	Name	I/O	Description	Type
24	I+MB (BISS_DATA+MB)	IN	Quadrature encoder I positive BiSS-C data positive motor B	Differential Digital Input
25	I-MB (BISS_DATA-MB)	IN	Quadrature encoder I negative BiSS-C data negative motor B	Differential Digital Input
26	Brake-MA	OUT	Motor A Brake Driver	Brake
27	Brake+MA	OUT	Motor A Brake Driver	Brake
28	Brake-MB	OUT	Motor B Brake Driver	Brake
29	Brake+MB	OUT	Motor B Brake Driver	Brake
30	5VDC_OUT	OUT	5 Volt Encoder/Hall/Aux Power	Low Voltage Power
31	SIGNAL_GND	---	5VDC_OUT Return and Ground Reference ⁽²⁾	Ground
32	A+MA (BISS_CLK+MA)	IN OUT	Quadrature encoder A positive BiSS-C clock positive motor A	Differential Digital Input Differential Digital Output
33	A-MA (BISS_CLK-MA)	IN OUT	Quadrature encoder A negative BiSS-C clock negative motor A	Differential Digital Input Differential Digital Output
34	B+_MA	IN	Quadrature encoder B positive motor A	Differential Digital Input
35	B-_MA	IN	Quadrature encoder B negative motor A	Differential Digital Input
36	I+MA (BISS_DATA+MA)	IN	Quadrature encoder I positive BiSS-C data positive motor A	Differential Digital Input
37	I-MA (BISS_DATA-MA)	IN	Quadrature encoder I negative BiSS-C data negative motor A	Differential Digital Input
38	HALL_A_MB (DIGIAL_IN_4)	IN	Hall A motor B DIGIAL_IN_4	Open Collector Input
39	HALL_B_MB (DIGIAL_IN_5)	IN	Hall B motor B DIGIAL_IN_5	Open Collector Input
40	HALL_C_MB (DIGIAL_IN_6)	IN	Hall C motor B DIGIAL_IN_6	Open Collector Input
41	5VDC_OUT	OUT	5 Volt Encoder/Hall/Aux Power	Low Voltage Power
42	SIGNAL_GND	---	5VDC_OUT Return and Ground Reference	Ground
43	HALL_A_MA (DIGIAL_IN_1)	IN	Hall A motor A DIGIAL_IN_1	Open Collector Input
44	HALL_B_MA (DIGIAL_IN_2)	IN	Hall B motor A DIGIAL_IN_2	Open Collector Input
45	HALL_C_MA (DIGIAL_IN_3)	IN	Hall C motor A DIGIAL_IN_3	Open Collector Input
46	5VDC_OUT	OUT	5 Volt Encoder/Hall/Aux Power	Low Voltage Power
47	SIGNAL_GND	---	5VDC_OUT Return and Ground Reference ⁽²⁾	Ground
48	Reserved	---	Do not connect	
49	Reserved	---	Do not connect	
50	Reserved	---	Do not connect	
51	Reserved	---	Do not connect	
52	Reserved	---	Do not connect	
53	Reserved	---	Do not connect	
54	Reserved	---	Do not connect	
55	Reserved	---	Do not connect	

NOTES:

- ESI recommends terminating all shields in the connector back-shell if possible. Chassis connection are included for systems without back-shell termination.

This document does not contain Technical Data or Technology as defined the ITAR Part 120.10 or EAR Part

J3 System Pinout Assignments

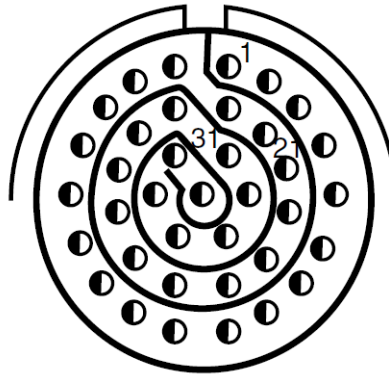

View looking into case connector

J3 Pin	Name	I/O	Description	Type
1	CH_GND	---	Chassis Ground ⁽¹⁾	Chassis Ground
2	28VDC_IN	IN	28 VDC In	Low Voltage Power
3	28VDC_IN	IN	28 VDC In	Low Voltage Power
4	Reserved	---	Do Not Connect	
5	28VDC_RTN	---	28 VDC Return	Low Voltage Power
6	RS422_TX+	OUT	RS422 Tx (+)	RS-422
7	RS422_TX-	OUT	RS422 Tx (-)	RS-422
8	RS422_RX+	IN	RS422 Rx (+)	RS-422
9	RS422_RX-	IN	RS422 Rx (-)	RS-422
10	Reserved	---	Do Not Connect	
11	Reserved	---	Do Not Connect	
12	28VDC_RTN	---	28 VDC Return	Low Voltage Power
13	Reserved	IN	Do Not Connect	
14	SIGNAL_GND	---	5VDC_OUT Return and Ground Reference	Ground
15	ANALOG_IN_1+ (CMD+_MA)	IN	Analog In 1 (+), <i>can be used as Command Positive Motor A</i>	±10 Volt Analog Input
16	ANALOG_IN_1- (CMD-_MA)	IN	Analog In 1 (-), <i>can be used as Command Negative Motor A</i>	±10 Volt Analog Input
17	ANALOG_IN_2+ (CMD+_MB)	IN	Analog In 2 (+), <i>can be used as Command Positive Motor B</i>	±10 Volt Analog Input
18	ANALOG_IN_2- (CMD-_MB)	IN	Analog In 2 (-), <i>can be used as Command Negative Motor B</i>	±10 Volt Analog Input
19	SIGNAL_GND	---	Ground Reference for all interface signals except the Isolated CAN	Ground
20	USB_D+	I/O	USB D+	USB
21	USB_D-	I/O	USB D-	USB
22	USB_VBUS	IN	USB Voltage Sense	USB
23	SIGNAL_GND	---	5VDC_OUT Return and Ground Reference	Ground
24	Reserved	---	Do Not Connect	
25	SIGNAL_GND	---	5VDC_OUT Return and Ground Reference	Ground
26	Reserved	---	Do Not Connect	
27	ANALOG_OUT_1	OUT	Analog Output 1 can be bound to any internal variable	Analog Output

J3 Pin	Name	I/O	Description	Type
28	ANALOG_OUT_2	OUT	Analog Output 2 can be bound to any internal variable	Analog Output
29	Reserved	---	Do not connect	
30	Reserved	---	Do not connect	
31	ISO_GND	---	Isolated CAN Ground Reference	Low Voltage Power
32	SIGNAL_GND	---	5VDC_OUT Return and Ground Reference	Ground
33	CAN+	I/O	CAN_A High	CAN
34	CAN-	I/O	CAN_A Low	CAN
35	ISO_CAN+	I/O	Isolated CAN High	ISO_CAN
36	ISO_CAN-	I/O	Isolated CAN Low	ISO_CAN
37	5VDC_OUT	OUT	5 Volt Encoder/Hall/Aux Power	Low Voltage Power

NOTES:

1. ESI recommends terminating all shields in the connector back-shell if possible. Chassis connection are included for systems without back-shell termination.

J4 Motor Pinout Assignments

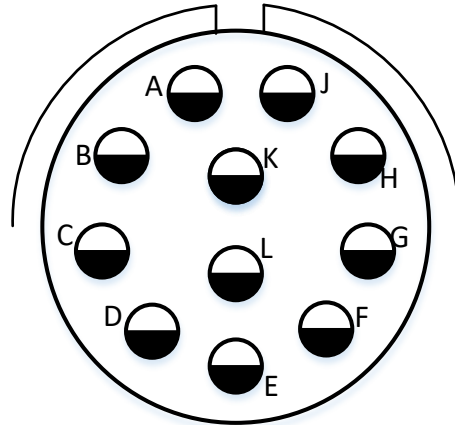

View looking into case connector

J4 Pin	Name	I/O	Description	Type
A	A_MA	OUT	Motor A Phase A	Motor Power
B	B_MA	OUT	Motor A Phase B	Motor Power
C	C_MA	OUT	Motor A Phase C	Motor Power
D	BRAKE+MA	OUT	Motor A Brake	Brake
E	BRAKE-MA	OUT	Motor A Brake Return	Brake
F	INTERLOCK+MA	IN	Interlock Loop Positive	Interlock
G	C_MA	OUT	Motor A Phase C	Motor Power
H	B_MA	OUT	Motor A Phase B	Motor Power
J	A_MA	OUT	Motor A Phase A	Motor Power
K	CH_GND	---	Chassis Ground	Chassis Ground
L	INTERLOCK-MA	IN	Interlock Loop Negative	Interlock

J5 Motor Pinout Assignments

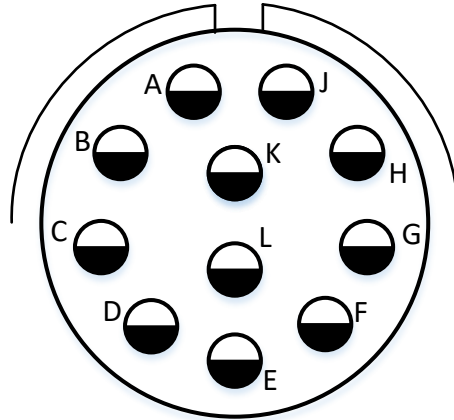

(View looking into chassis sockets)

J5 Pin	Name	I/O	Description	Type
A	A_MB	OUT	Motor B Phase A	Motor Power
B	B_MB	OUT	Motor B Phase B	Motor Power
C	C_MB	OUT	Motor B Phase C	Motor Power
D	BRAKE+MB	OUT	Motor B Brake	Brake
E	BRAKE-MB	OUT	Motor B Brake Return	Brake
F	INTERLOCK+MB	IN	Interlock Loop	Interlock
G	C_MB	OUT	Motor B Phase C	Motor Power
H	B_MB	OUT	Motor B Phase B	Motor Power
J	A_MB	OUT	Motor B Phase A	Motor Power
K	CH_GND	---	Chassis Ground	Chassis Ground
L	INTERLOCK-MB	IN	Interlock Loop Return	Interlock

Power Loss Curves

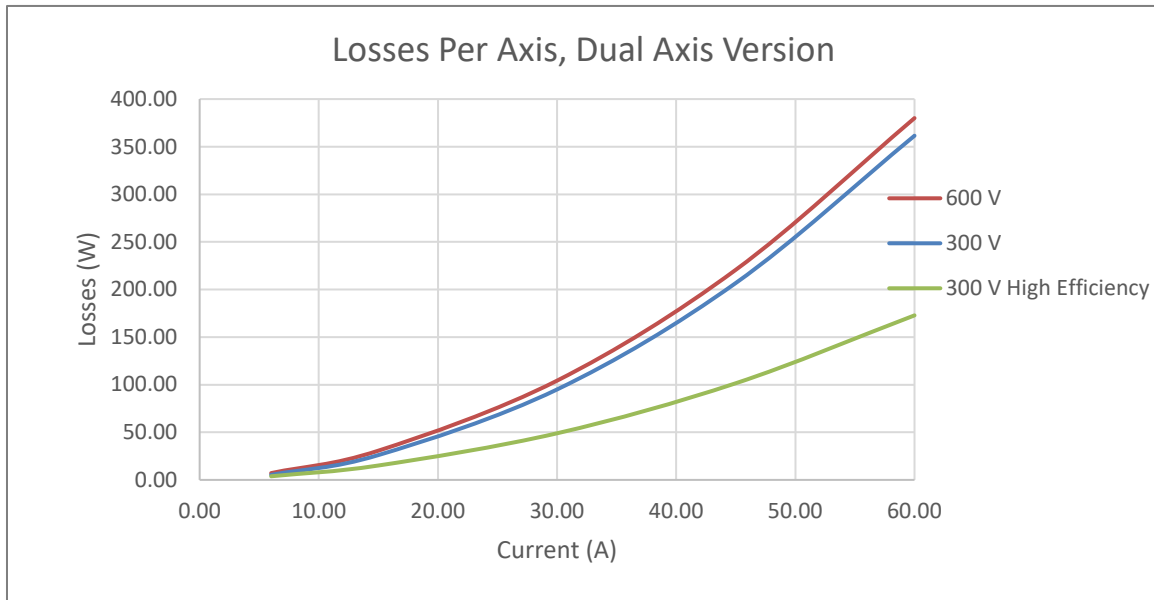
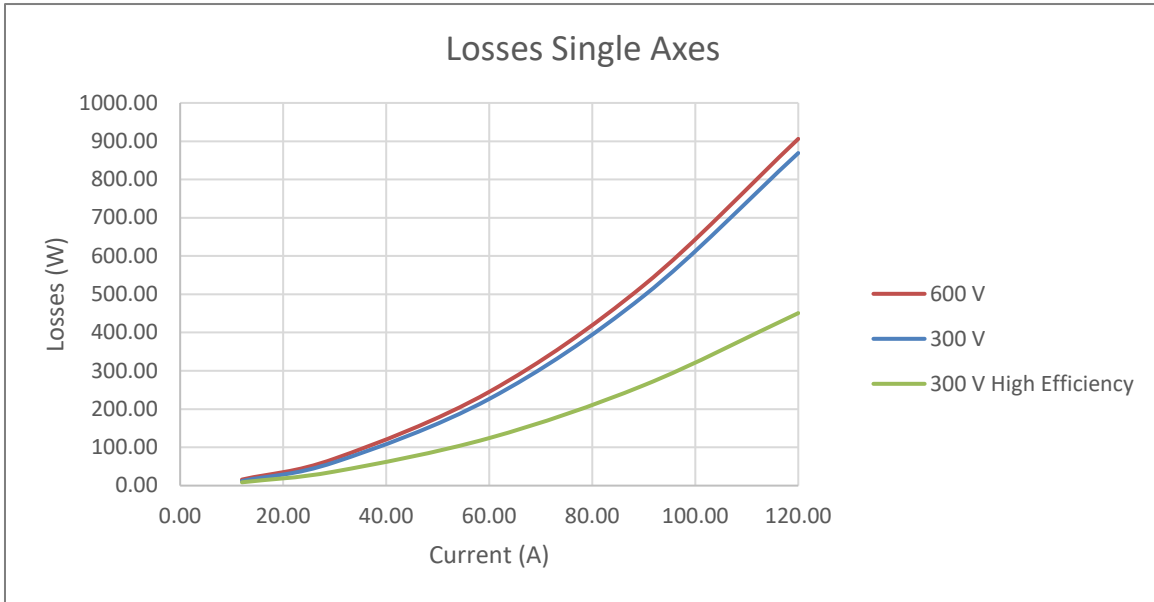

Ordering Information

Draco Servo Drive Configuration Options

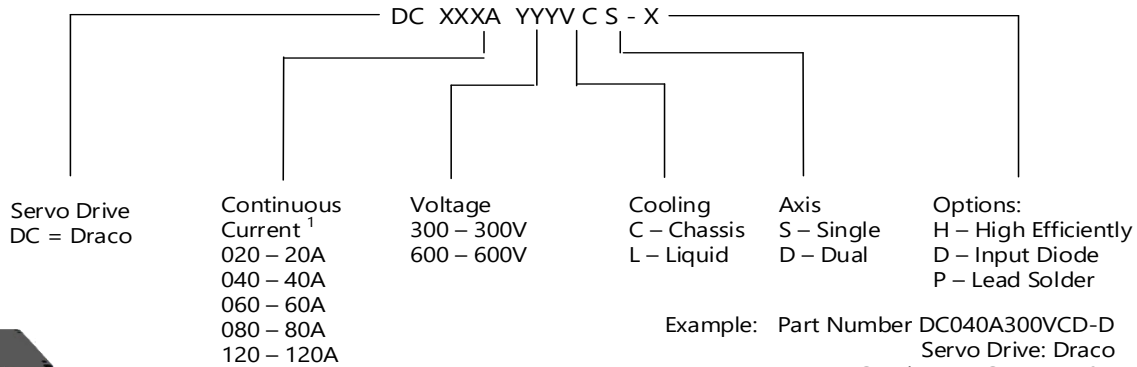

¹ Motor Phase Current, Peak Sine Wave, per Axis

Example: Part Number DC040A300VCD-D
 Servo Drive: Draco
 Continuous Current: 40A
 Nominal Voltage: 300V
 Cooling: Chassis
 Configuration: Dual-Axis
 Options: Input Diode

Model Availability List

Single-Axis:

Rated Current	300V	600V
20A	DC020A300VCS DC020A300VCS-H DC020A300VCS-D DC020A300VLS DC020A300VLS-H DC020A300VLS-D	DC020A600VCS DC020A600VCS-H DC020A600VCS-D DC020A600VLS DC020A600VLS-H DC020A600VLS-D
40A	DC040A300VCS DC040A300VCS-H DC040A300VCS-D DC040A300VLS DC040A300VLS-H DC040A300VLS-D	DC040A600VCS DC040A600VCS-H DC040A600VCS-D DC040A600VLS DC040A600VLS-H DC040A600VLS-D
60A	DC060A300VCS DC060A300VCS-H DC060A300VCS-D DC060A300VLS DC060A300VLS-H DC060A300VLS-D	Contact ESI
80A	DC080A300VCS DC080A300VCS-H DC080A300VCS-D DC080A300VLS DC080A300VLS-H DC080A300VLS-D	DC080A600VCS DC080A600VCS-H DC080A600VCS-D DC080A600VLS DC080A600VLS-H DC080A600VLS-D
120A	DC120A300VCS DC120A300VCS-H DC120A300VCS-D DC120A300VLS DC120A300VLS-H DC120A300VLS-D	Contact ESI

Dual-axis:

Rated Current	300V	600V
20A	DC020A300VCD DC020A300VCD-H DC020A300VCD-D DC020A300VLD DC020A300VLD-H DC020A300VLD-D	DC020A600VCD DC020A600VCD-H DC020A600VCD-D DC020A600VLD DC020A600VLD-H DC020A600VLD-D
40A	DC040A300VCD DC040A300VCD-H DC040A300VCD-D DC040A300VLD DC040A300VLD-H DC040A300VLD-D	DC040A600VCD DC040A600VCD-H DC040A600VCD-D DC040A600VLD DC040A600VLD-H DC040A600VLD-D
60A	DC060A300VCD DC060A300VCD-H DC060A300VCD-D DC060A300VLD DC060A300VLD-H DC060A300VLD-D	Contact ESI

Notes:

- Standard Products are shown in **bold**, and have expedited lead times.