

SuperNova

Dual-Axis Servo Drive



Radiation Tolerant Motion Control for LEO and GEO Applications

The SuperNova Radiation-Tolerant Servo Controller represents a groundbreaking advancement in engineering, designed to withstand the harshest radiation environments with unwavering precision and reliability. Utilizing radiation-tolerant components and innovative shielding techniques, this controller ensures seamless operation even in the presence of intense radiation. Its robust construction and sophisticated algorithms enable precise control of servo motors in critical applications such as **ultraprecise gimble** positioning, **reaction wheel** control, **SADA** control, **Thrust Vector** control, and general-purpose space exploration. With unparalleled resilience and accuracy, the SuperNova Radiation-Tolerant Servo Controller sets a new standard for performance and safety in high-risk environments, empowering missions and operations where reliability is paramount. ESI Motion's SuperNova leads the industry with its **specifically designed for LEO, and GEO motion control** applications. The SuperNova is a **low profile, lightweight, Dual-Axis Controller** that is one of the **few COTS servo drives for a high-performance space application on the market today!**

Features:

- Fully Digital High-Performance Drive
- 20 Amps Continuous Motor Current
- Max power: 400W
- 40 kHz PWM Frequency Standard (Consult factory for frequencies up to 100 kHz)
- Multiple Feedbacks Included
 - Serial Encoder over LVDS or RS-422
 - Resolver
 - Hall
- Communication Interfaces
 - CAN
 - RS-422
- Torque, Velocity, or Position control
- Dual-Axis Embedded Motion Controller
- Configurable, user-friendly GUI with Integrated Oscilloscope (HiDS)
- Chassis-cooled
- Motor Type: 3-Phase Permanent Magnet

Specifications:

- Single Power Input / Bus Voltage: 28 VDC
- Input current up to 14 A
- Output Power: 200W per axis
- Efficiency >95% (full load)
- Operating Temperature: -40 °C to 71 °C
- Unit Weight: 435 (0.96lbs.) - 499g (1.1 lbs.)
- Unit Size: 165 mm x 85.8 mm x 22.8 mm (6.5" x 3.38" x 0.9")

Radiation Tolerance:

- TID: 30 kRad
- SEL: 37 Let MeV (Non-Destructive)
- Custom Options are available for Polar and Interplanetary Missions. These may require a tailored testing procedure to ensure mission success. Please contact ESI for more information.

This document does not contain Technical Data or Technology as defined the ITAR Part 120.10 or EAR Part 772.

Compliance:

- Software Design Assurance: DO-178C Option
 - IPC-610 Class III High-Performance Assembly
 - Electromagnetic Interference per MIL-STD-461*:
 - CE102 ○ CS116
 - CS101 ○ RE101
 - CS114 ○ RE102
 - CS115 ○ RS103
 - Environmental qualification per MIL-STD-810:
 - Random Vibration (X, Y & Z axes): 17.23 Grms, 20 – 2,000 Hz (0.15 g²/Hz)
 - SRS Shock (X, Y & Z axes): 60 to 200 G's, 100 – 750 Hz. 200 G's, 750 – 10,000 Hz.
- Electrical power characteristics: MIL-STD-704

Customization Available

ESI Motion has the expertise to customize a solution for your project's needs. Contact us today at sales@esimotion.com to see how we can tailor a solution for you.

*The EMI features on ESI's SuperNova are being sold AS-IS, without warranty. EMI compliance is a complex requirement involving the controller, cabling, and the motor. All parts in the system will require special consideration in order to fully comply with EMI features. Due to this complexity, ESI does not warrant system level EMI compliance.

ESI offers EMI certification services. Certification services can be customized to your needs and typically include a system EMI review, formal compliance testing, and a compliance report. Please contact ESI for details on how to get your system certified to MIL-STD-461.

Typical SuperNova Application:

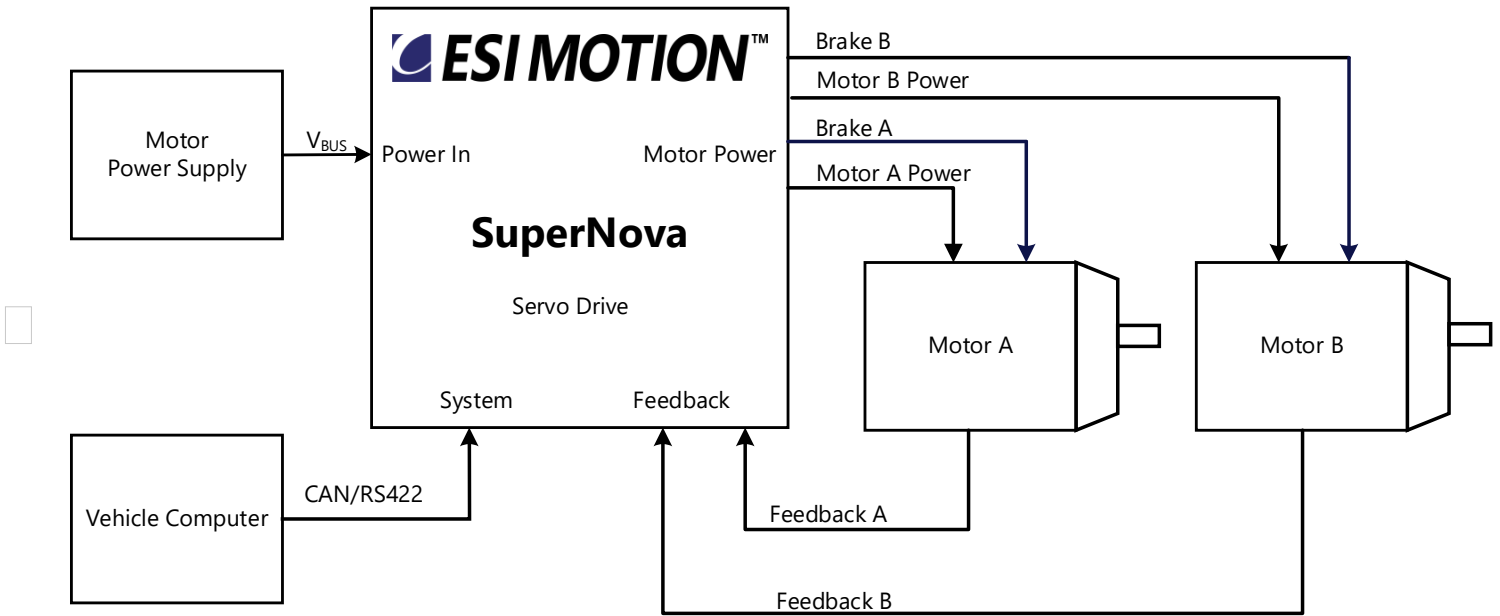

SuperNova Block Diagram:

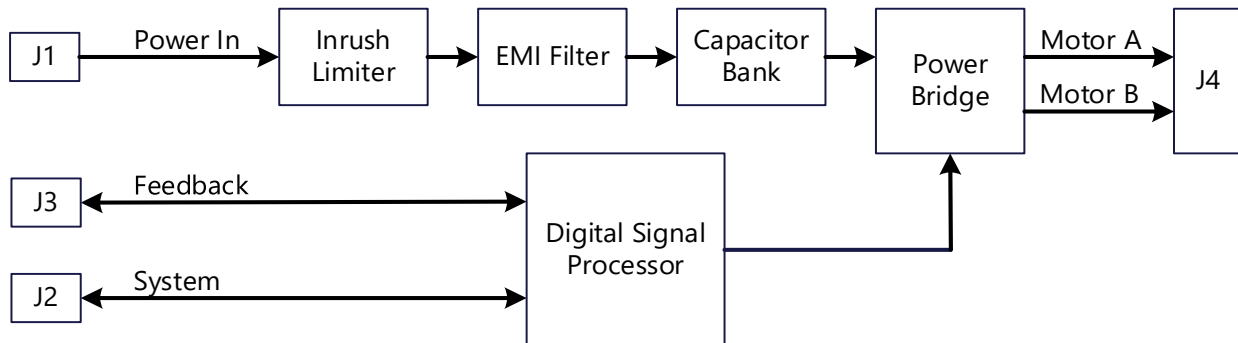

This document does not contain Technical Data or Technology as defined the ITAR Part 120.10 or EAR Part 772.

Electrical Specifications

Absolute Maximum Values

The values in the table below should never be exceeded as permanent damage to the controller may result.

PARAMETER		ABSOLUTE MAXIMUM	UNIT
V_BUS (Motor Power)		65	VDC
±10 Volt Analog Inputs		±22	V
±5 Volt Analog Inputs (Resolver Inputs)		±22	V
Single Ended Analog Input		±22	V
Open Collector Inputs (Hall Inputs)		±10	V
CAN Network (CAN+ and CAN-)	Differential (CAN+ – CAN-)	±36	V
	Common-Mode	±36	V
RS-422 Inputs		±14	V
Differential Digital Inputs (Encoder)	Differential (Assumes 50% Duty Cycle)	3.0	V
	Common-mode	-5 to +6	V
Digital Input		±10	V
Temperature Sensor Input		-3 to +9	V
Storage Temperature		-55 to +100	°C

Recommended Operating Conditions

DC INPUT CHARACTERISTICS				
PARAMETER	MIN	NOM	MAX	UNIT
V_BUS	22	28	29	VDC
V_BUS Input Current while Idle		0.15		A
V_BUS Input Current			14	A
V_BUS Input Power		392	406	W
Internal Bus Capacitance (Differential Mode)		184		uF
Chassis Capacitance (Common Mode) ⁽¹⁾		25		uF

Notes:

- Total for V_BUS and V_BUS_RTN.

This document does not contain Technical Data or Technology as defined the ITAR Part 120.10 or EAR Part 772.

POWER OUTPUT CHARACTERISTICS				
PARAMETER	MIN	NOM	MAX	UNIT
Motor A_MA, B_MA, C_MA, A_MB, B_MB, C_MB				
Output Current		14	20 ⁽¹⁾	Amps Peak-of-Sin
Brake BRAKE+MA, BRAKE-MA, BRAKE+MB, BRAKE-MB				
Output Voltage			94%	Percent of 28VDC_IN
Output Current Limit	1	2	4	Amps
Feedback Power 5VDC_OUT				
Output Voltage	4.75	5.0	5.25	VDC
Output Current		500		mA

Notes:

- Two Second Peak

ANALOG I/O CHARACTERISTICS				
PARAMETER	MIN	NOM	MAX	UNIT
±10 Volt Analog Inputs ANALOG_IN_1, ANALOG_IN_2, ANALOG_IN_3, ANALOG_IN_4, ANALOG_IN_5, ANALOG_IN_6				
Input Range	-10		+10	V
Common Mode Input Range	-8.0	0	+10.0	V
Impedance		20.0		KΩ
Input Bandwidth		100		kHz
ADC Sampling Resolution		12		Bits
Digital In				
Input Voltage Range	-0.3		5	
High Level Input Voltage	2.0			V
Low Level Input Voltage			0.8	V
Motor Temperature MOTOR_TEMP+, MOTOR_TEMP-				
Thermistor Resistance at 25°C	1	5	10	KΩ
Recommended Thermistor Resistance at 25°C		5		KΩ
Recommended B _{25/85}		3480		
Recommended B _{0/100}		3450		
Recommended B _{25/00}		3497		
Excitation Voltage		3.0		V
Excitation Impedance		2.0		kOhm

This document does not contain Technical Data or Technology as defined the ITAR Part 120.10 or EAR Part 772.

ANALOG I/O CHARACTERISTICS				
PARAMETER	MIN	NOM	MAX	UNIT
Input Bandwidth		1.6		kHz
Resolver Excitation EXE+MA, EXE-MA, EXE+MB, EXE-MB				
Output Voltage	3.8	4	4.2	V _{RMS}
Resolver Excitation Output Frequency ⁽¹⁾		10		kHz
Resolver SIN, COS (ANALOG_IN_2 – ANALOG_IN_6) SIN+MA, SIN-MA, COS+MA, COS-MA, SIN+MB, SIN-MB, COS+MB, COS-MB				
Differential Range	2		4.2	V _{RMS}
Differential Impedance		20		KΩ
Input Bandwidth		100		kHz

Notes:

1. Default Resolver Frequency is 10 kHz. Contact Factory for custom frequencies.

DIGITAL I/O CHARACTERISTICS				
PARAMETER	MIN	NOM	MAX	UNIT
CAN Signals CAN+, CAN-				
Voltage Levels	Compliant to ISO 11898-2			
Standard Bit Rates	100, 250, 500, and 1,000			Kbps
Open Collector Inputs (HALL Inputs) HALL_A_MA, HALL_B_MA, HALL_C_MA, HALL_A_MB, HALL_B_MB, HALL_C_MB Alternate Function Name DIGITAL_IN_1, DIGITAL_IN_2, DIGITAL_IN_3, DIGITAL_IN_4, DIGITAL_IN_5, DIGITAL_IN_6,				
Input Voltage	0		10	V
Internal Pull Up Voltage	4.5	5.0	5.5	V
Internal Pull Up Impedance		1.0		kOhm
Logic High Voltage		1.95		V
Logic Low Voltage		1.07		V
Input Hysteresis		0.88		V
RS422 Signals RS422_TX, RS422_RX				
Voltage Levels	Compliant to EIA-422-B			
Standard Bit Rates	115.2, 230.4			Kbps
Serial Encoder POS+_MA, POS-_MA, CLK+_MA, CLK-_MA, CMD+_MA, CMD-_MA, POS+_MB, POS-_MB, CLK+_MB, CLK-_MB, CMD+_MB, CMD-_MB,				
Voltage Levels	EIA-422-B (RS-422) or TIA/EIA-644 (LVDS) (must be specified at time of order)			
Differential Input Impedance	120			Ohms
Input Frequency	25			MHz

This document does not contain Technical Data or Technology as defined the ITAR Part 120.10 or EAR Part 772.

Thermal Specifications

Thermal Specifications				
PARAMETER	Min	Nom	Max	UNIT
Maximum Case Temperature	-40		71	°C

Mechanical Specifications

Mechanical Specifications				
PARAMETER	Min	Nom	Max	UNIT
Weight		0.43 (0.96)	0.50 (1.1)	kg (lbs)
Size Length Width Height		165 (6.5) 85.8 (3.38) 22.8 (0.9)		mm (in)

Connector Information

No.	Function	Number of contacts	Contact size	Connector Part Number	Mating Connector Part Number
J1	Input Power	25	26	MWDM2L-25PCBRR5-.110	MWDM2L-25SSM
J2	System	21	26	MWDM2L-21SCBRR5-.110	MWDM2L-21PSM
J3	Motor Feedback	51	26	MWDM2L-51PCBRR5-.110	MWDM2L-51SSM
J4	Motor Output	51	26	MWDM2L-51SCBRR5-.110	MWDM2L-51PSM

This document does not contain Technical Data or Technology as defined the ITAR Part 120.10 or EAR Part 772.

Interconnect Diagram

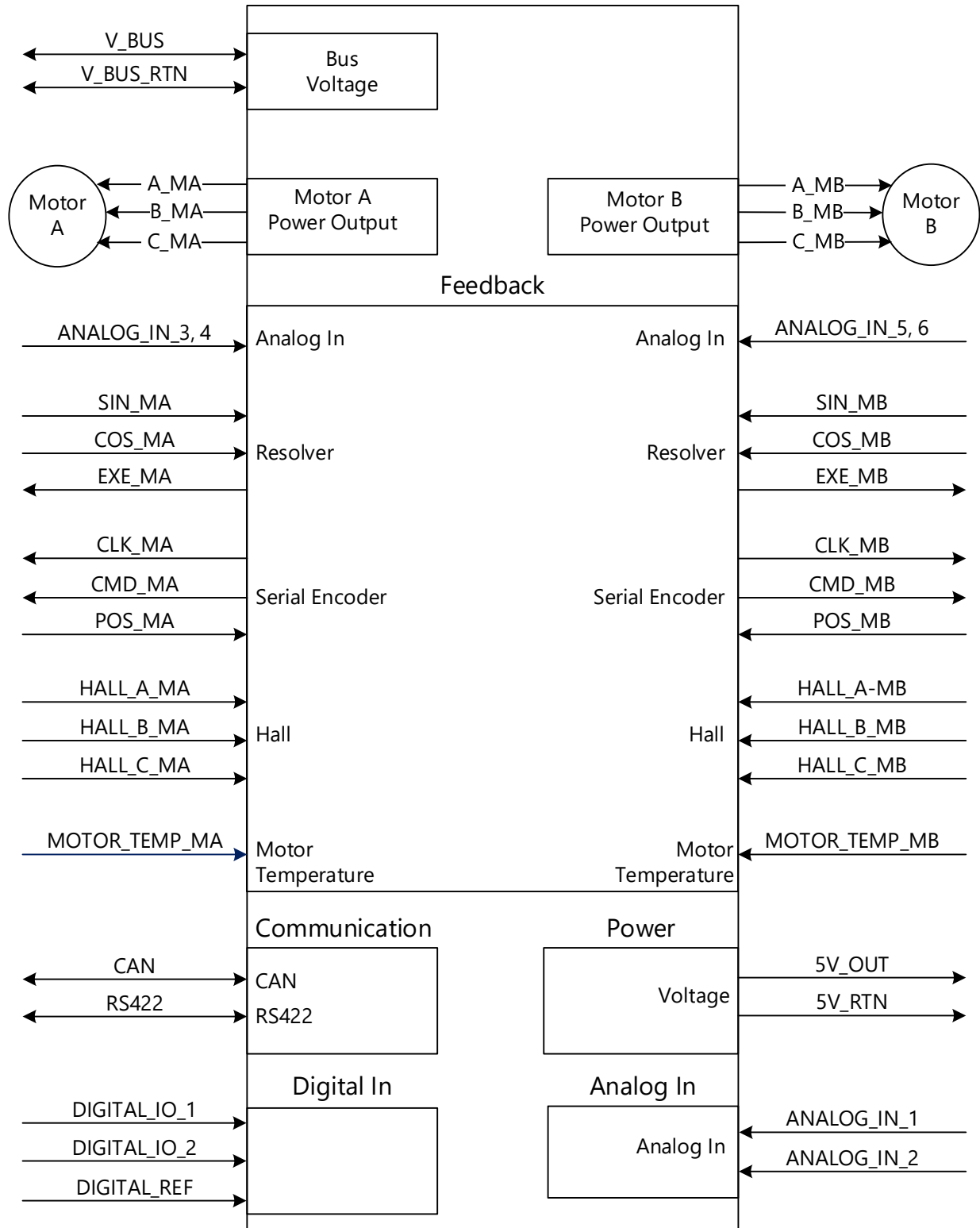

This document does not contain Technical Data or Technology as defined the ITAR Part 120.10 or EAR Part 772.

Interfaces Description

Power Input

V_BUS Voltage is the input used for motor power and logic power.

Motor Power Output

Dedicated motor power pins are provided for Motor A and Motor B. The motors are controlled independently.

Motor Feedback

The SuperNova Servo Drive supports the following motor feedback devices:

- Resolver
- Serial Encoder over LVDS or RS-422
- Hall

Feedback selection is software configurable. ESI recommends that digital feedback devices (i.e. Serial Encoder or Halls) are powered from the 5VDC_OUT supplied by SuperNova.

Temperature Sensor Input

The temperature inputs accept a Negative Temperature Coefficient (NTC) thermistor. The software linearizes the NTC output. The sensor linearization is configurable through entry of a polynomial.

Communication Interface

The SuperNova includes a CAN and RS-422 interface. The user must provide external termination resistors on the CAN network.

Analog Inputs

The SuperNova includes 10 analog inputs of the following types and quantities:

- ± 10 Volt Differential x Six Inputs
- ± 5 Volt Differential x Four Inputs

These inputs can be scaled and mapped to the current command, velocity command, or position command. They can also be used to enable or disable the drive. This analog input is provided to support legacy analog systems – ESI recommends CAN or RS-422 if the system allows.

Digital In Digital Inputs are also provided. They can be mapped to several functions via software, i.e. Drive Enable.

Heatsink

The SuperNova is chassis cooled.

Built-In Protection

The SuperNova Servo Drive includes numerous protections. For details, please refer to the Software User's Manual. A partial list of the built-in protection follows:

- Over Current
- Over Voltage
- Under Voltage
- Controller Over Temperature
- Motor Over Temperature
- Over Speed
- Loss of Feedback

DO-178C Safety Critical Certification

For applications requiring DO-178C certification, ESI Motion has designed SuperNova's Baseline Software, which can be tailored to your system's requirements, resulting in a lower time to deployment, cost savings and reduced risk.

ESI Motion’s HiDS Application

The Host Interface for Drive/Servo Controller (HiDS) is ESI Motion’s servo motor controller software configuration tool.

This innovative application allows users to configure a servo motor control system quickly, and with a great deal of flexibility. It’s based upon a configurable, user-friendly GUI, with an integrated oscilloscope feature. Extensive data collection and control allows system tuning and troubleshooting.

HiDS functions require connection to the CAN network. The HiDS tool and the Software User’s Manual can be downloaded from ESI Motion’s website.

The user can set the drive mode to either current, velocity, or position control. Each of these control loops utilizes a Proportional, Integral, and Derivative (PID) filter. The Software User’s Manual includes a procedure for tuning each loop.

The Software User’s Manual walks you through the steps to set up limits, enter motor parameters, and feedback types. An excerpt from the HiDS tool is shown below.

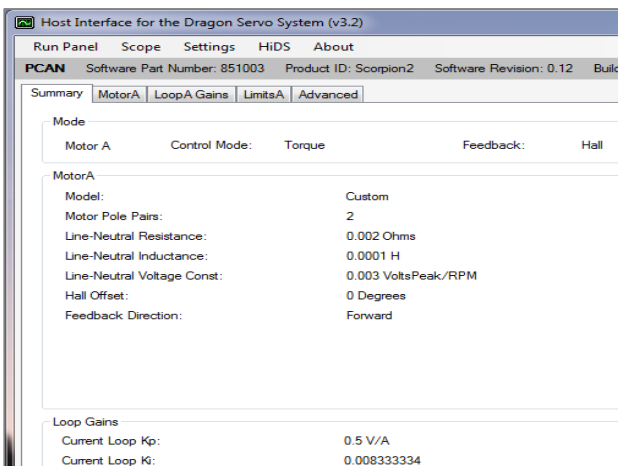

HiDS allows extreme flexibility via simply changing parameters, without the need to reload custom software.

The HiDS Run Panel facilitates control commands and monitoring of parameters such as motor speed and current.



A typical velocity-loop step response, displayed on the built-in oscilloscope function, is shown below.

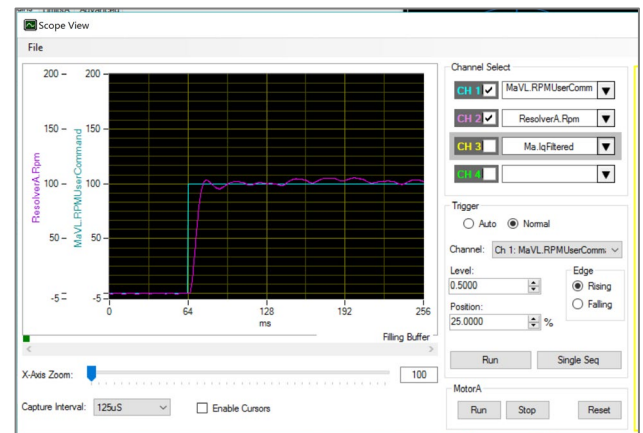

The SuperNova Servo Drive and HiDS tool allow for tremendous flexibility in motor control and monitoring. This capability ensures success of the most challenging motion control applications.

Connector Pinouts

Interfaces for each SuperNova connectors are shown in this section. See each respective diagram for the pinout numbering.

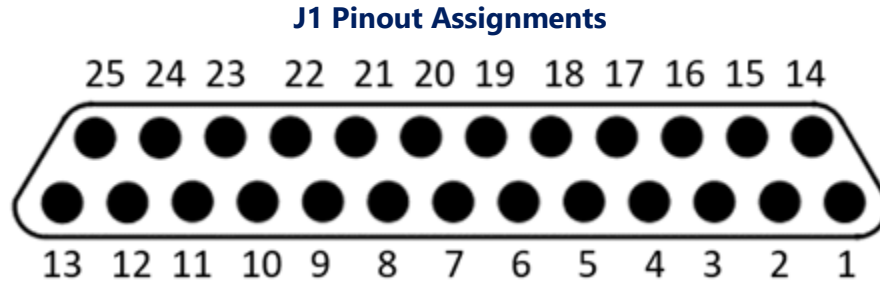

Figure 1 – J1 Input Power Connector Pinout (Facing into Connector)

J1 PIN	NAME	I/O	DESCRIPTION	TYPE
1	V_BUS_RTN	IN	Motor Power Return	Power
2	V_BUS_RTN	IN	Motor Power Return	Power
3	V_BUS_RTN	IN	Motor Power Return	Power
4	V_BUS_RTN	IN	Motor Power Return	Power
5	V_BUS_RTN	IN	Motor Power Return	Power
6	V_BUS_RTN	IN	Motor Power Return	Power
7	V_BUS	IN	Motor Power	Power
8	V_BUS	IN	Motor Power	Power
9	V_BUS	IN	Motor Power	Power
10	V_BUS	IN	Motor Power	Power
11	V_BUS	IN	Motor Power	Power
12	V_BUS	IN	Motor Power	Power
13	V_BUS	IN	Motor Power	Power
14	V_BUS_RTN	IN	Motor Power Return	Power
15	V_BUS_RTN	IN	Motor Power Return	Power
16	V_BUS_RTN	IN	Motor Power Return	Power
17	V_BUS_RTN	IN	Motor Power Return	Power
18	V_BUS_RTN	IN	Motor Power Return	Power
19	V_BUS_RTN	IN	Motor Power Return	Power
20	V_BUS	IN	Motor Power	Power
21	V_BUS	IN	Motor Power	Power
22	V_BUS	IN	Motor Power	Power
23	V_BUS	IN	Motor Power	Power
24	V_BUS	IN	Motor Power	Power
25	V_BUS	IN	Motor Power	Power

This document does not contain Technical Data or Technology as defined the ITAR Part 120.10 or EAR Part 772.

J2 Pinout Assignments

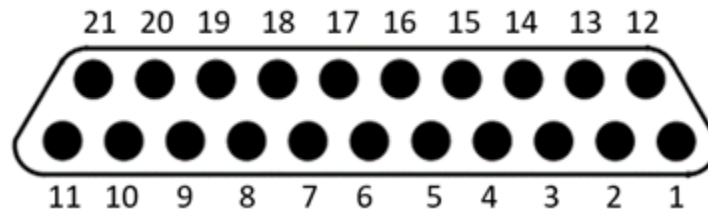

Figure 2 - J2 System Connector Pinout (Facing into Connector)

J2 PIN	NAME	I/O	DESCRIPTION	TYPE
1	RS422_TX+	OUT	RS422 Tx (+)	RS-422
2	ISO_GND	---	Isolated Communication Ground Reference	Ground
3	CAN+	I/O	CAN_A High	CAN
4	CAN-	I/O	CAN_A Low	CAN
5	DIGITAL_INPUT_1	IN	User Configurable Digital Input	Digital Input
6	DIGITAL_INPUT_2	IN	User Configurable Digital Input	Digital Input
7	BOOT_CAN+	I/O	Boot CAN High	CAN
8	BOOT_CAN-	I/O	Boot CAN Low	CAN
9	ANALOG_IN_2-	IN	Analog In 2 (-)	±10 Volt Analog Input
10	MAINTENANCE	IN	Maintenance Mode Enable	Digital Input
11	SIGNAL_GND	---	5VDC_OUT Return and Ground Reference	Ground
12	RS422_TX-	OUT	RS422 Tx (-)	RS-422
13	RS422_RX-	IN	RS422 Rx (-)	RS-422
14	ISO_GND	---	Isolated Communication Ground Reference	Ground
15	RS422_RX+	IN	RS422 Rx (+)	RS-422
16	SIGNAL_GND	---	5VDC_OUT Return and Ground Reference	Ground
17	ANALOG_IN_1+	IN	Analog In 1 (+)	±10 Volt Analog Input
18	ANALOG_IN_1-	IN	Analog In 1 (-)	±10 Volt Analog Input
19	ANALOG_IN_2+	IN	Analog In 2 (+)	±10 Volt Analog Input
20	BOOT_EN	IN	Boot Mode Enable	Digital Input
21	Reserved	---	Do not connect	

This document does not contain Technical Data or Technology as defined the ITAR Part 120.10 or EAR Part 772.

J3 Pinout Assignments

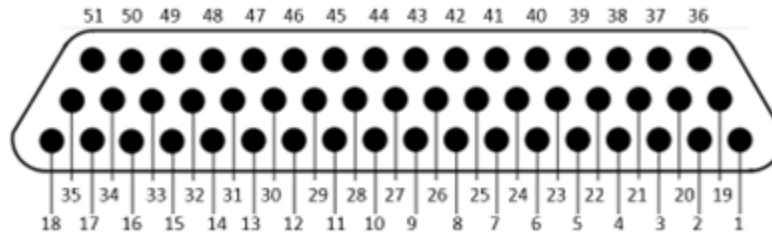

Figure 3 – J3 Feedback Connector Pinout (Facing into Connector)

J3 PIN	NAME	I/O	DESCRIPTION	TYPE
1	CLK+MA	OUT	Clock to Encoder Positive Motor A	LVDS or RS-422 Output
2	CLK-MA	OUT	Clock to Encoder Negative Motor A	LVDS or RS-422 Output
3	DOUT+MA	OUT	Data to Encoder Positive Motor A	LVDS or RS-422 Output
4	DOUT-MA	OUT	Data to Encoder Negative Motor A	LVDS or RS-422 Output
5	DIN+MA	IN	Data from Encoder Positive Motor A	LVDS or RS-422 Input
6	DIN-MA	IN	Data from Encoder Negative Motor A	LVDS or RS-422 Input
7	CLK+MB	OUT	Clock to Encoder Positive Motor B	LVDS or RS-422 Output
8	CLK-MB	OUT	Clock to Encoder Negative Motor B	LVDS or RS-422 Output
9	CMD+MB	OUT	Data to Encoder Positive Motor B	LVDS or RS-422 Output
10	CMD-MB	OUT	Data from Encoder Negative Motor B	LVDS or RS-422 Output
11	POS+MB	IN	Data from Encoder Positive Motor B	LVDS or RS-422 Input
12	POS-MB	IN	Data from Encoder Negative Motor B	LVDS or RS-422 Input
13	SIGNAL_GND	---	5VDC_OUT Return	Ground
14	SIGNAL_GND	---	5VDC_OUT Return	Ground
15	5VDC_OUT	OUT	5 Volt Encoder/Hall/Aux Power	Power
16	5VDC_OUT	OUT	5 Volt Encoder/Hall/Aux Power	Power
17	MOTOR_TEMP+MA	IN	Temperature Positive Motor A	Temperature Input
18	MOTOR_TEMP-MA	IN	Temperature Negative Motor A	Temperature Input
19	COS+MB	IN	Resolver COS Positive Motor B	Resolver Input
20	SIN+MB	IN	Resolver SIN Positive Motor B	Resolver Input
21	COS-MB	IN	Resolver COS Negative Motor B	Resolver Input
22	SIN-MB	IN	Resolver SIN Negative Motor B	Resolver Input
23	COS+MA	IN	Resolver COS Positive Motor A	Resolver Input
24	SIN+MA	IN	Resolver SIN Positive Motor A	Resolver Input
25	COS-MA	IN	Resolver COS Negative Motor A	Resolver Input
26	SIN-MA	IN	Resolver SIN Negative Motor A	Resolver Input
27	SIGNAL_GND	---	5VDC_OUT Return	Ground
28	MOTOR_TEMP+MB	OUT	Temperature Positive Motor B	Temperature Input
29	Reserved	---	Do not connect	
30	MOTOR_TEMP-MB	IN	Temperature Negative Motor B	Temperature Input

This document does not contain Technical Data or Technology as defined the ITAR Part 120.10 or EAR Part 772.

31	HALL_A_MB	IN	Hall A Motor B	Open Collector Input
32	ANALOG_IN_5+	IN	Analog Input 5+	±5 Volt Analog Input
33	HALL_B_MB	IN	Hall B Motor B	Open Collector Input
34	ANALOG_IN_5-	IN	Analog Input 5-	±5 Volt Analog Input
35	HALL_C_MB	IN	Hall C Motor B	Open Collector Input
36	EXE+MB	OUT	Resolver Excitation Positive Motor B	Resolver Output
37	EXE-MB	OUT	Resolver Excitation Negative Motor B	Resolver Output
38	EXE+MA	OUT	Resolver Excitation Positive Motor A	Resolver Output
39	EXE-MA	OUT	Resolver Excitation Negative Motor A	Resolver Output
40	SIGNAL_GND	---	5VDC_OUT Return	Ground
41	5VDC_OUT	OUT	5 Volt Encoder/Hall/Aux Power	Power
42	HALL_A_MA	IN	Hall A Motor A	Open Collector Input
43	HALL_B_MA	IN	Hall B Motor A	Open Collector Input
44	ANALOG_IN_6+	IN	Analog Input 6 Positive	±5 Volt Analog Input
45	HALL_C_MA	IN	Hall C Motor A	Open Collector Input
46	5VDC_OUT	OUT	5 Volt Encoder/Hall/Aux Power	Power
47	ANALOG_IN_6-	IN	Analog Input 6 Negative	±5 Volt Analog Input
48	ANALOG_IN_4+	IN	Analog Input 4 Positive	±5 Volt Analog Input
49	ANALOG_IN_4-	IN	Analog Input 4 Negative	±5 Volt Analog Input
50	ANALOG_IN_3+	IN	Analog Input 3 Positive	±5 Volt Analog Input
51	ANALOG_IN_3-	IN	Analog Input 3 Negative	±5 Volt Analog Input

This document does not contain Technical Data or Technology as defined the ITAR Part 120.10 or EAR Part 772.

J4 Pinout Assignments

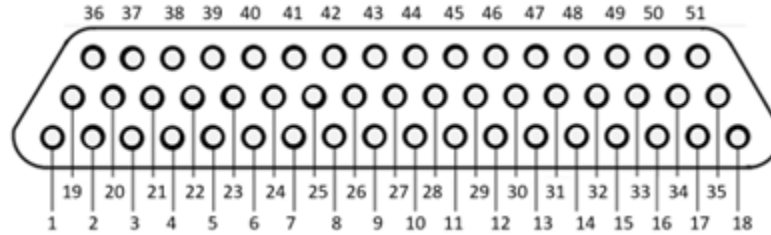

Figure 4 – J4 Motor Connector Pinout (Facing into Connector)

J4 PIN	NAME	I/O	DESCRIPTION	TYPE
1	A_MA	OUT	Motor A Phase A	Power
2	A_MA	OUT	Motor A Phase A	Power
3	A_MA	OUT	Motor A Phase A	Power
4	A_MA	OUT	Motor A Phase A	Power
5	BRAKE-MA	OUT	Motor A Brake Return	Power
6	BRAKE-MA	OUT	Motor A Brake Return	Power
7	BRAKE-MA	OUT	Motor A Brake Return	Power
8	BRAKE-MA	OUT	Motor A Brake Return	Power
9	BRAKE+MA	OUT	Motor A Brake	Power
10	BRAKE+MA	OUT	Motor A Brake	Power
11	BRAKE-MB	OUT	Motor B Brake Return	Power
12	BRAKE-MB	OUT	Motor B Brake Return	Power
13	BRAKE-MB	OUT	Motor B Brake Return	Power
14	BRAKE-MB	OUT	Motor B Brake Return	Power
15	A_MB	OUT	Motor B Phase A	Power
16	A_MB	OUT	Motor B Phase A	Power
17	A_MB	OUT	Motor B Phase A	Power
18	A_MB	OUT	Motor B Phase A	Power
19	A_MA	OUT	Motor A Phase A	Power
20	C_MA	OUT	Motor A Phase C	Power
21	A_MA	OUT	Motor A Phase A	Power
22	C_MA	OUT	Motor A Phase C	Power
23	BRAKE-MA	OUT	Motor A Brake Return	Power
24	C_MA	OUT	Motor A Phase C	Power
25	BRAKE-MA	OUT	Motor A Brake Return	Power
26	B_MA	OUT	Motor A Phase B	Power
27	BRAKE+MB	OUT	Motor B Brake	Power
28	B_MB	OUT	Motor B Phase B	Power
29	BRAKE-MB	OUT	Motor B Brake Return	Power
30	C_MB	OUT	Motor B Phase C	Power
31	BRAKE-MB	OUT	Motor B Brake Return	Power
32	C_MB	OUT	Motor B Phase C	Power
33	A_MB	OUT	Motor B Phase A	Power

This document does not contain Technical Data or Technology as defined the ITAR Part 120.10 or EAR Part 772.

34	C_MB	OUT	Motor B Phase C	Power
35	A_MB	OUT	Motor B Phase A	Power
36	C_MA	OUT	Motor A Phase C	Power
37	C_MA	OUT	Motor A Phase C	Power
38	C_MA	OUT	Motor A Phase C	Power
39	B_MA	OUT	Motor A Phase C	Power
40	B_MA	OUT	Motor A Phase C	Power
41	B_MA	OUT	Motor A Phase C	Power
42	B_MA	OUT	Motor A Phase C	Power
43	B_MB	OUT	Motor B Phase B	Power
44	B_MA	OUT	Motor A Phase C	Power
45	B_MB	OUT	Motor B Phase B	Power
46	B_MB	OUT	Motor B Phase B	Power
47	B_MB	OUT	Motor B Phase B	Power
48	B_MB	OUT	Motor B Phase B	Power
49	C_MB	OUT	Motor B Phase C	Power
50	C_MB	OUT	Motor B Phase C	Power
51	C_MB	OUT	Motor B Phase C	Power

This document does not contain Technical Data or Technology as defined the ITAR Part 120.10 or EAR Part 772.

Envelope and Dimensions

Mechanical Dimensions

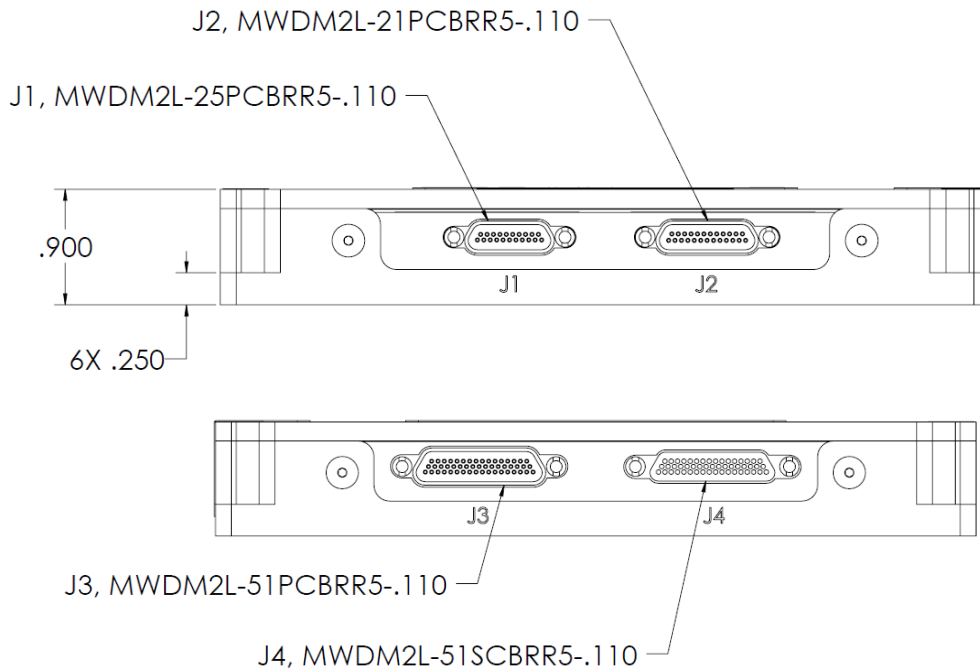
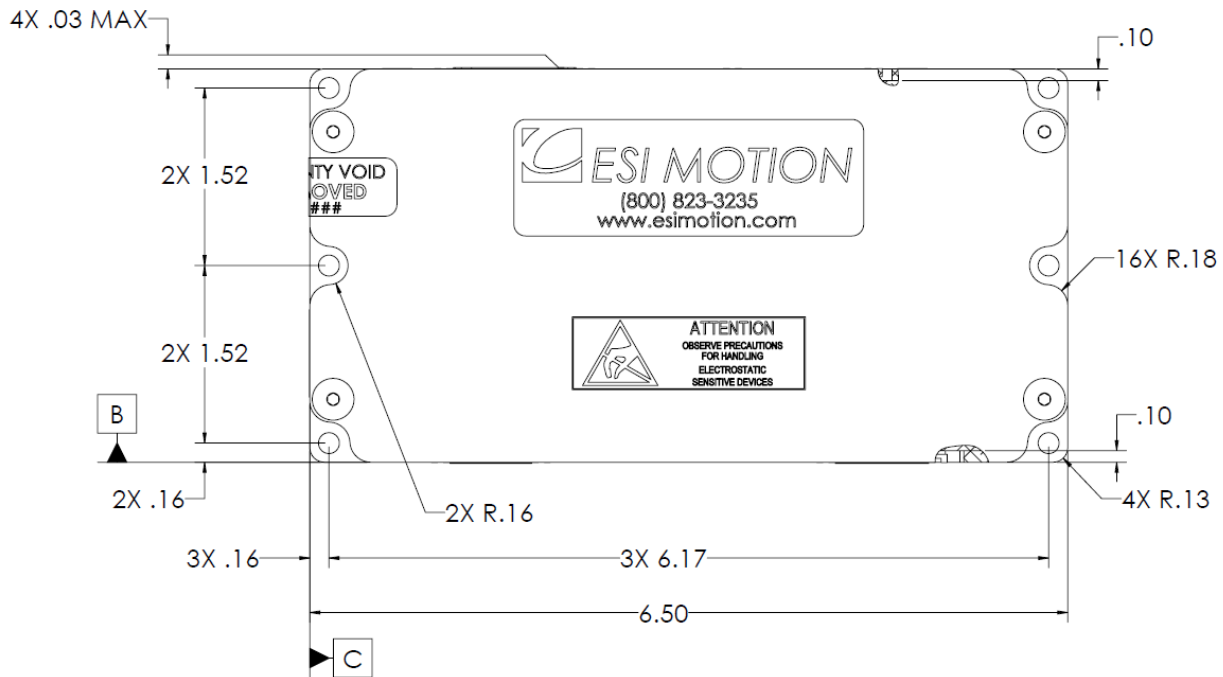

This document does not contain Technical Data or Technology as defined the ITAR Part 120.10 or EAR Part 772.

Front

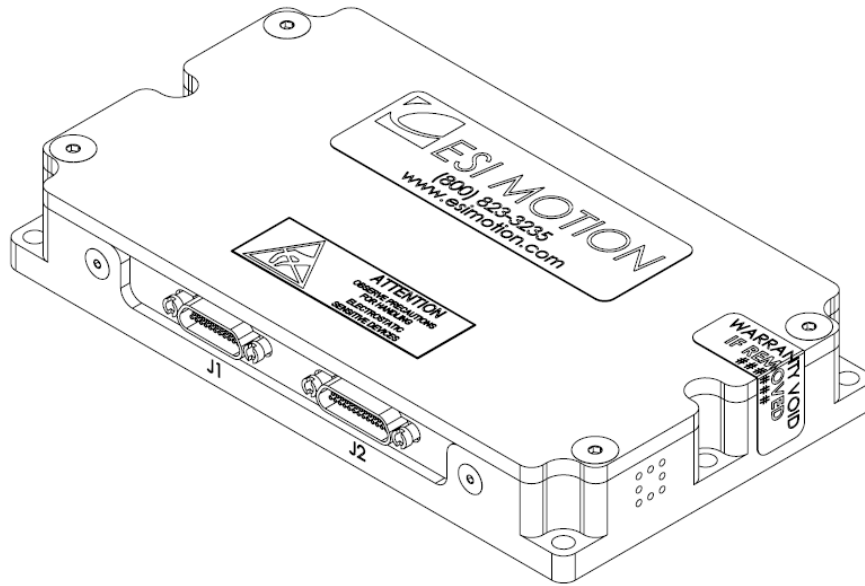

Back

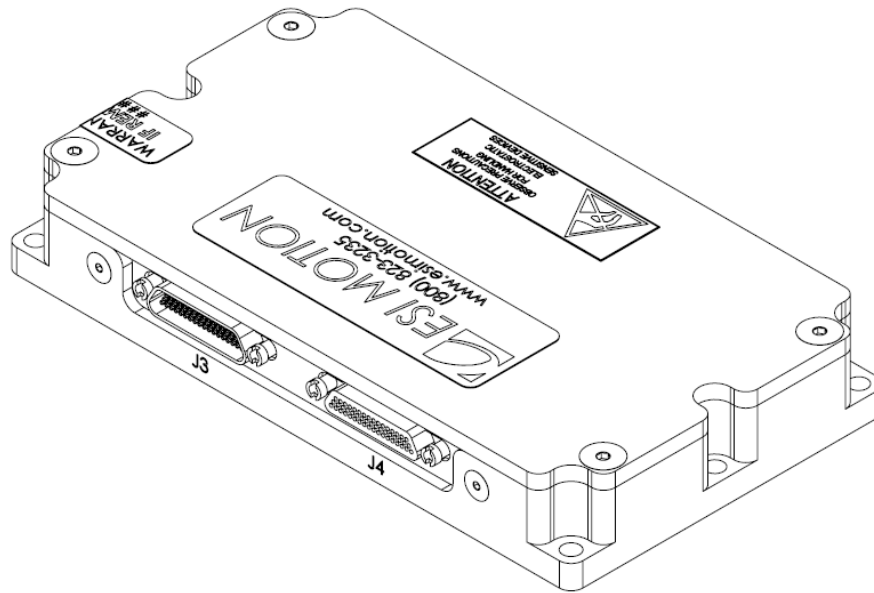

This document does not contain Technical Data or Technology as defined the ITAR Part 120.10 or EAR Part 772.

Thermal Information

The typical power loss curves are shown below for the Dual-Axis Configurations. The curve assume the controller is running hot.

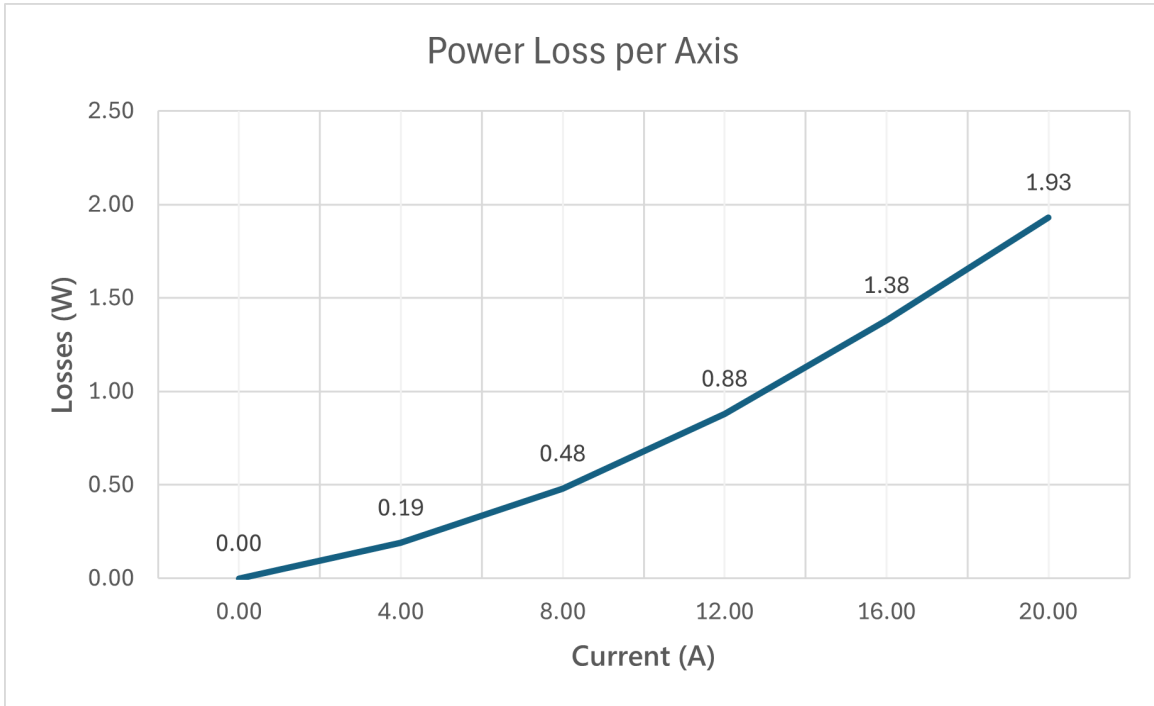

This document does not contain Technical Data or Technology as defined the ITAR Part 120.10 or EAR Part 772.

Ordering Information

SuperNova Servo Drive Configuration Option

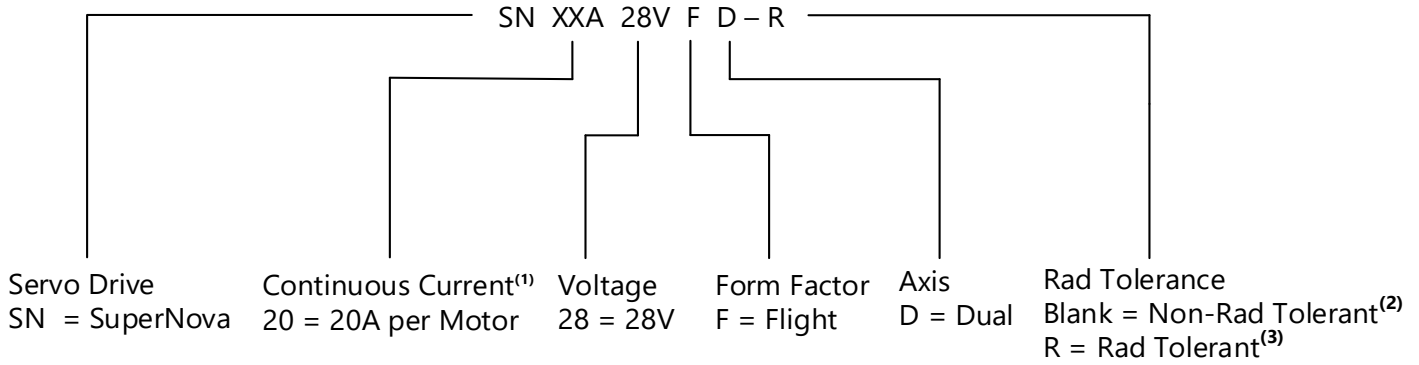

1. Peak Sine Wave, per axis. Consult factory for higher current options.
2. Engineering Development Unit
3. Radiation Tolerant Option includes Space-Rated, Outgassed connectors

Example

Part Number: SN20A28VFD-R
 Servo Drive: SuperNova
 Continuous Current: 20 Amp Total
 Max Bus Voltage: 28 VDC
 Form Factor: Flight
 Motor Axis: Dual-Axis
 Rad Tolerant: Yes



Model Availability List

The following table lists available models:

Dual-Axis:		Notes: 1. Radiation Tolerant Option available. 2. Please contact ESI for Customization, other feedback options or motor types.
20A	SN20A028VFD SN20A028VFD-R	
A/V	28V	

This document does not contain Technical Data or Technology as defined the ITAR Part 120.10 or EAR Part 772.